

On the Semantics of Comparative Correlatives in Mandarin Chinese

Jo-wang Lin

National Chiao Tung University

Abstract

The main goal of this article is to provide a formal semantics of comparative correlatives of the form “*yuè*... , (*jiù*) *yuè*...” in Mandarin Chinese. A new analysis is proposed which treats the comparative correlatives as involving a quantificational tripartite structure and derives all the meanings of the “*yuè*... , (*jiù*) *yuè*...” constructions through comparison of degrees related to different or the same individual. The comparison of the same or different individuals’ degrees of a given property is shown to be consequences of Partee’s suggested general processing strategy for noun phrase interpretation as well as the constituent structure of the sentence. It is also shown that the same semantics for Chinese *yuè* can be extended to the *-er* in English “the Adj-er...the Adj-er...” constructions or similar constructions in other languages, at the same time deriving the superficial cross-linguistic variation from independent factors.

1. Introduction

Mandarin Chinese has a special construction consisting of two clauses each of which contains a *yuè* ‘more’ morpheme. In addition to *yuè* ‘more’, the second clause of this construction may optionally contain the morpheme *jiù*, which is sometimes translated as *then* in English. This is illustrated in (1)-(3) below.

(1) nǐ yuè shēngqì , tā (jiù) yuè gāoxìng

you more angry he JIU more happy

‘The angrier you are, the happier he is.’

(2) wǒ yuè zhuī tā , tā (jiù) yuè pǎo

I more chase him he JIU more run

‘The more I chased him, the more he ran.’

(3) tā yuè dà , (jiù) yuè piàoliàng

she more big JIU more beautiful

‘The older she becomes, the more beautiful she is.’

The most special semantic feature of the above construction is that the increasing degree change of the property denoted by the first clause causes the increasing degree change of the property denoted by the second clause. Lü (1982:367-369) refers to the above phenomenon as dependent change [*yǐbiàn* in terms of Chinese] and Xing (2001: 378) dubs such constructions as constructions of conditional dependent change [*tiáojiàn yǐbiàn jù* in terms of Chinese].

Intuitively, it seems to make sense to refer to the “*yuè... yuè...*” constructions as a kind of conditional, because their semantics are quite close to those of regular conditionals. On the one hand, the meaning of (1) is almost equivalent to (4) or (5), where a conditional connective is inserted, as Liu (2006) has pointed out.

(4) *rúguǒ nǐ yuè shēngqì , tā (jiù) yuè gāoxìng*
 if he more angry he then more happy
 ‘lit. If you are angrier, he is then happier.’

(5) *zhǐyào nǐ yuè shēngqì , tā (jiù) yuè gāoxìng*
 as-long-as you more angry he then more happy
 ‘lit. As long as you are angrier, he is happier.’

On the other hand, the “*yuè... yuè...*” constructions are the Chinese counterparts to the English “the -er...the -er” constructions in terms of translation. For instance, (1) is the Chinese counterpart to the English sentence below.

(6) The angrier you are, the happier he is.

Interestingly, constructions like (6) have been thought of as a kind of conditional. For example, McCawley (1988) refers to this construction as “comparative conditionals”, a term which has also been adopted by Beck (1997) and others.

Despite the semantic similarity between the “*yuè... yuè...*” constructions and the normal conditionals, the “*yuè... yuè...*” constructions are actually not fully equivalent to *rúguǒ*- or *zhǐyào*-conditionals (*if* or *as-long-as* conditionals). There is at least one difference between the two constructions. Namely, while the “*yuè... yuè...*” constructions may describe an on-going situation or a fact that has happened in the past as Xing (2001: 379-380) has already observed, *rúguǒ*- or *zhǐyào*-conditionals may not. To illustrate, consider (7). This sentence may describe an on-going situation in which more and more guests are coming at the speech time and hence the foods may not be enough. In (8), both the events of her scolding me and my getting angry took place yesterday.

- (7) kèrén yuè lái yuè duō , shíwù kěnéng huì bú gòu
 guest more come more many food possibly will not enough
 ‘More and more guests are coming, so the foods may be not enough.’
- (8) zuótiān tā yuè mà wǒ , wǒ jiù yuè shēngqì ,
 Yesterday he more scold me I then more angry
 suǒyǐ wǒ jiù bù gēn tā jiǎng huà le
 so I then not with him say word Par
 ‘Yesterday, the more he scolded me, the angrier I got. So I decided not to talk with him.’

Now if the conditional morpheme *rúguǒ* is inserted to (7) and (8), the meaning is either changed or the sentence is simply ungrammatical as is shown in (9) and (10). (9) only has a meaning indicating a possibility instead of describing a fact.¹ (10) is an unacceptable sentence and cannot be used as a counterfactual conditional.²

- (9) rúguǒ kèrén yuè lái yuè duō , shíwù kěnéng huì bú gòu
 if guest more come more many food possibly will not enough
 ‘If more and more people come, the foods may not be enough.’
- (10) *zuótiān rúguǒ tā yuè mà wǒ , wǒ jiù yuè shēngqì
 Yesterday if he more scold me I then more angry
 ‘Yesterday, if he scolded me more, I would get more angry.’

Very interestingly, the properties that the “*yuè... yuè...*” constructions display are quite similar to those properties exhibited by what Cheng and Huang (1998) refer to as “bare conditionals”, in which a *wh*-phrase in the consequent clause is anaphoric to another *wh*-phrase in the antecedent clause. The construction of “bare conditionals” is illustrated by (11).

- (11) shéi xiān lái , shéi xiān chī
 who first come who first eat
 ‘Whoever comes first eats first.’

According to Lin (1996), a big difference between “bare conditionals” and regular conditionals is that the antecedent clause in a “bare conditional” may describe a fact as is shown in (12), whereas a *rúguǒ*-clause ‘if-clause’ only indicates a possibility as

¹ For this fact, see Lin (1996) for more discussion.

² This fact has been observed by Liu (2006).

is shown in (13).

(12) nǐ zuótiān gēn shéi yì zǔ , jīntiān jiù hái shì gēn
you yesterday with who one group today then still be with
shéi yì zǔ
whom one group

‘lit. Whoever you were in the same group with yesterday, you will still be in the same group with him today.’

(13) rúguǒ zuótiān shéi méi jiāo zuòyè dehuà , jīntiān tā
if yesterday who not hand-in homework if today he
jiù bìxū bǔjiāo
then must make-up

‘If someone didn’t hand in his homework yesterday, he must do so today.’

(13) does not entail that someone did not hand in his homework but (12) entails that you were in the same group with someone. On the basis of this difference, Lin (1996) concludes that “bare conditionals” are not elliptical *rúguǒ*-conditionals “if-conditionals”. By parity of Lin’s reasoning, we can conclude that the “*yuè*... *yuè*...” constructions are not elliptical *rúguǒ*-conditionals.

Although the “*yuè*... *yuè*...” constructions are not elliptical *rúguǒ*-conditionals, their semantics is much similar to the latter. Therefore, in this article, I will approach the semantics of the “*yuè*... *yuè*...” constructions in a way linguists have treated regular conditionals. However, in what follows I will dub the “*yuè*... *yuè*...” constructions as comparative correlatives, because I do not know whether or not they are really a kind of conditional³, nor will I defend such a view.

The main goal of this article is to provide a formal semantics of comparative correlatives, discussing how the semantics of the morpheme *yuè* ‘more’ looks like. In addition to this general goal, this article will in particular pay attention to the following issues. First, when the subject NP of a *yuè*-predicate is a bare noun, why is it that sometimes we are comparing different individuals with respect to the degrees of a given property, but some other times we are comparing the same individual’s different degrees of a given property? For instance, in (14), which contains an individual-level predicate in the first clause, we are comparing the degrees of beautifulness of different girls, but in (15), which contains a stage-level predicate in the first clause, we tend to compare the same individual’s different degrees of nervousness.

³ This problem particularly stands out when we consider cases where the first occurrence of *yuè* is embedded to a relative clause, as will be discussed later in section 6.

- (14) nǚháizi yuè piàoliàng , (jiù) yuè duō rén zhuī
 girl more beautiful then more many man chase
 ‘The more beautiful a girl is, the more men will chase her.’
 ‘ $\forall x, y[\text{girl}(x) \ \& \ \text{girl}(y) \ \& \ y \text{ is more beautiful than } x][\text{more men chase } y \text{ than } x]$ ’⁴
- (15) xuéshēng yuè jǐnzhāng , (jiù) yuè róngyì kǎo de bù
 student more nervous then more easy take-exam DE not
 hǎo
 good
 ‘The more nervous a student is, the easier it is for him to not do well in an exam.’
 ‘ $\forall x, s, s'[\text{student}(x) \ \& \ x \text{ is more nervous in situation } s \text{ than in } s'] [x\text{'s performance is worse in } s \text{ than in } s']$ ’

Curiously, however, if the first clause in (15) is turned into a complex NP with a relative clause, we will be comparing different individuals’ degrees of nervousness instead of the same individual’s different degrees of nervousness.

- (16) yuè jǐnzhāng de xuéshēng (jiù) yuè róngyì kǎo de
 more nervous REL student then more easy take-exam DE
 bù hǎo
 not good
 ‘ $\forall x, y[\text{student}(x) \ \& \ \text{student}(y) \ \& \ x \text{ is more nervous than } y][x\text{'s performance is worse than } y]$ ’

Another goal of this article is to argue that the different interpretations of comparative correlatives in Mandarin Chinese may be due to Partee’s (2004) proposed processing strategy of semantic interpretation as stated in (17) as well as the constituent structure of a given comparative correlative .

(17) Partee’s General Processing Strategy

there is a general processing strategy of trying lowest types first, using higher types only when they are required in order to combine meanings by available compositional rules. (Partee 2004: 204-205)

Finally, in addition to Chinese comparative correlatives, this paper will discuss their counterpart constructions in English, aiming to provide a possible universal

⁴ The logical representations in (14)-(16) are not intended as analyses of the examples but as helpful indicators of the meaning.

semantics of comparative correlatives across languages.

This article is organized as follows. Section 2 is a brief review of Hsiao's (2003) view of the semantics of comparative correlatives, showing that her proposal is not correct. Section 3 is a summary of Beck's (1997) analysis of comparative conditionals. Section 4 argues that her analysis of comparative conditionals may not be directly extended to Chinese and motivates a new analysis of Chinese comparative correlatives. Section 5 makes a new proposal of the semantics of the morpheme *yuè* 'more' and the construction containing *yuè* 'more' as a whole. Section 6 is an extension of the analysis proposed in section 5 to complex NPs with a relative clause. Section 7 further shows how the proposed semantics of *yuè* accounts for the cooccurrence between *yuè* and an overt item of comparison, which is not allowed in English comparative conditionals. Finally, section 8 concludes this article, sketching a possible direction for a unifying semantics of cross-linguistic comparative correlative constructions.

2. Hsiao's (2003) Analysis of Chinese Comparative Correlatives

The most recent published semantic analysis of Chinese comparative correlatives that I know of is Hsiao's (2003) work, in which she suggests that comparative correlatives express a proportional reading. According to her, the first *yuè* 'more' in a comparative correlative contains an independent variable X, whereas the second *yuè* contains a dependent variable Y. The value of the degree or quantity of Y changes with that of the degree or quantity of X. The meaning of the construction is expressed in terms of the following formula:

$$(18) y = ax + b$$

In mathematics, the *a* and *b* in (18) stand for constants, and *b* can be the number zero. Now let us suppose that *a* = 2, *b* = 0, and *x* and *y* are positive natural numbers. We will get the following result.

$$(19) \begin{aligned} 2 &= 2 \times 1 + 0 \\ 4 &= 2 \times 2 + 0 \\ 6 &= 2 \times 3 + 0 \\ 8 &= 2 \times 4 + 0 \\ &\dots \end{aligned}$$

In other words, the value of *y* is always two times the value of *x*. So the two values are

proportional.

Now the question is: Do comparative correlatives really express a proportional function as Hsiao (2003) has suggested? Take (20) as an example.

- (20) Zhāngsān yuè pǎo yuè kuài
Zhangsan more run more fast
'The more Zhangsan runs, the faster he is.'

Suppose that (20) represents a proportional meaning and *Zhangsan's* speed is measured in terms of the distance that he can run per second. Further assume that *Zhangsan* runs five meters at the first second. Then according to the formula in (18), his speed should be 10 meters per second at the next second and 15 meters per second at the third second, and so on and so forth. Does (20) really express such a proportional meaning? This proportional interpretation is possible, but (20) does not need to have such a proportional interpretation. What is really required for a sentence like (20) to be true is only that the speed at a later second is faster than the speed at the previous second. It is not necessary that the speed at a later second must be proportional to the speed at the previous second. For example, (20) may perfectly describe the following scenario, though there is no proportional relation between the speeds at two adjacent seconds.

- (21) The speed at the first second is 3 meters per second
The speed at the second second is 3.5 meters per second
The speed at the third second is 5 meters per second
The speed at the fourth second is 6 meters per second
The speed at the fifth second is 6.7 meters per second

Clearly, in the above scenario, the speed at the later second has no fixed proportional relation to the speed at the previous second. I conclude that Hsiao's treatment of comparative correlatives as "proportional correlative constructions" may not adequately account for the semantics of such constructions.⁵

3. Beck's (1997) Analysis of English Comparative Conditionals

It was noted at the outset of this article that the Chinese comparative correlatives has been argued to be the Mandarin Chinese equivalent of the English comparative conditionals. It is therefore helpful to see how such constructions are analyzed in the

⁵ Also see Liu (2006) for a similar conclusion.

literature.

The most detailed semantic analysis of such constructions is provided by Beck (1997).⁶ In accordance with earlier works such as Wold (1991), she analyzes comparative conditionals as a special kind of conditional which involves correlative constructions as von Fintel (1994) has suggested. Her semantic analysis of comparative conditionals is mainly based on two assumptions. First, comparative conditionals display many properties similar to those of regular conditions as discussed in Heim (1982) and therefore we may use Heim's theory of conditionals to analyze comparative conditionals. Second, both the antecedent and consequent clause in a comparative conditional involve two compared items. So the semantics of comparison must be incorporated into the semantics of comparative conditionals. In the following, I will summarize Beck's treatment of comparative conditionals with respect to the above two points.

In order to explain donkey anaphora in English, Heim (1982), following Lewis (1975), analyzes conditionals as involving a quantificational tripartite structure, in which the *if*-clause is the restriction of a possibly implicit quantifier or adverb of quantification and the consequent clause is the nuclear scope. The quantifier or adverb of quantification may freely select a free variable within its scope to bind. For example, according to Heim, both indefinites and donkey pronouns can be analyzed as free variables. Therefore, an (implicit) adverb of quantification may bind the variables introduced by them, as shown in (22)-(23).

- (22) a. If a man owns a donkey, he beats it.
b. $\forall x,y[\text{man}'(x) \wedge \text{donkey}'(y) \wedge \text{own}'(x,y)][\text{beat}'(x,y)]$
- (23) a. If a man owns a donkey, he usually/sometimes beats it.
b. MOST/SOME $x,y[\text{man}'(x) \wedge \text{donkey}'(y) \wedge \text{own}'(x,y)][\text{beat}'(x,y)]$

As for the semantics of comparison, Beck (1997) proposes the following analysis for English comparative clauses. She adopts a maximal degree analysis for comparison. Therefore, the semantics of (24a) is (24c).

- (24) a. Louise is (3cm) taller than Otto (is tall).
b. $-\text{er}'(\lambda d[\text{tall}'(d, \text{Otto})](3 \text{ cm})(\lambda d[\text{tall}'(d, \text{Louise})])$
c. $\text{The max } d_1[\text{tall}'(d_1, \text{Louise})] = 3 \text{ cm} + \text{the max } d_2[\text{tall}'(d_2, \text{Otto})]$

According to the above analysis of comparison, the comparative morpheme *-er* takes

⁶ See also Thiersch (1982), Fillmore (1987), Culicover and Jackendoff (1999), Borsley (2004) and Dikken (2005) and references cited there for other discussions of the syntax and semantics of comparative conditionals.

three arguments, as shown in (25).

$$(25) \llbracket [-er] \rrbracket (D_1)(d)(D_2) = 1 \text{ iff the max } d_2 D_2(d_2) = d + \text{ the max } d_1 D_1(d_1)$$

But we know that the difference argument sometimes need not be present. Beck suggests that such difference arguments are existentially closed. Therefore, when *-er* takes only two arguments, its semantics is as in (26). The meaning of (24a) without the difference argument is then (27).

$$(26) \llbracket [-er] \rrbracket (D_1)(D_2) = 1 \text{ iff } \exists d[d > 0 \ \& \ \text{the max } d_2 D_2(d_2) = d + \text{ the max } d_1 D_1(d_1)$$

$$(27) \exists d[d > 0 \ \& \ \text{the max } d_2 [\text{tall}'(d_2, \text{Luise})] = d + \text{ the max } d_1 [\text{tall}'(d_1, \text{Otto})]]$$

Returning to comparative conditionals, Beck points out that they share many similarities with regular conditionals.

First, like regular conditionals, the default quantifier of a comparative conditional is a universal quantifier.

Second, like adverbs of quantification in regular conditionals, the quantifier in comparative conditionals may bind different variables such as individual variables, time variables or world variables. For instance, in (28), (29), and (30), what is quantified over is a world variable, individual variable and time variable, respectively.

(28) a. The better Otto is prepared, the better his talk will be.

$$\text{b. } \forall w_1 w_2 [\text{Otto is better prepared in } w_1 \text{ than in } w_2] \\ \Rightarrow [\text{Otto's talk is better in } w_1 \text{ than in } w_2]$$

(29) a. The slimier an attorney looks, the more successful he is.

$$\text{b. } \forall x, y [\text{attorney}(x) \ \& \ \text{attorney}(y) \ \& \ x \text{ looks slimier than } y] \\ \Rightarrow [x \text{ is more successful than } y]$$

(30) a. The hotter it is, the more tired Uli is.

$$\text{b. } \forall t_1, t_2 [\text{it was hotter at } t_1 \text{ than it was at } t_2] \\ \Rightarrow [\text{Uli was more tired at } t_1 \text{ than he was at } t_2]$$

Third, also like regular conditionals, though a universal operator is a default quantifier, an overt adverb of quantification may take over its job. This is illustrated in (31).

(31) a. The stronger a climber is, the better he usually is.

$$\text{b. MOST } x, y [\text{climber}(x) \ \& \ \text{climber}(y) \ \& \ x \text{ is stronger than } y] [x \text{ is better than } y].$$

In view of the above similarities between comparative conditionals and regular conditionals, Beck (1997) proposes to adopt Heim's (1982) analysis of regular conditionals. The only thing that is more complicated for comparative conditionals is that they involve additional semantics of comparison.

Beck proposes that both the first and the second clause in a comparative conditional is a CP projection, forming a correlative structure. The comparative morpheme *-er* projects a functional DP with *the* as the specifier. The whole DP is raised to the specifier position of CP, as is represented below.⁷

$$(32) \forall(\lambda w_1, w_2[\text{the}'(w_1, w_2)(-er')(\lambda w \lambda d[\text{well}'(d, \lambda x[\text{prepared}'_w(x)](\text{Otto}))])])]) \\ (\lambda w_1, w_2[\text{the}'(w_1, w_2)(-er')(\lambda w \lambda d[\text{good}'_w(d, \text{Otto's_talk})])])])$$

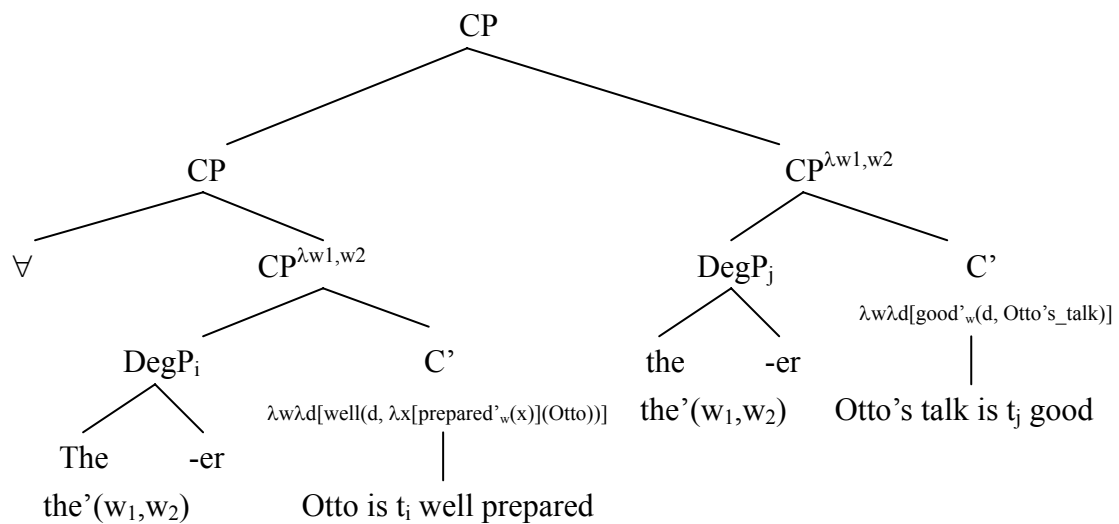

In (32), the default quantifier is the implicit universal quantifier, which takes the first clause as its first argument and the second clause the second argument. The representation in (32) clearly shows that the internal structures of the two clauses in question are exactly the same.

Apart from the above representation, another crucial component of Beck's analysis is the analysis of *the*. An important difference between normal comparatives and comparative conditionals is that the former may overtly provide the compared argument, i.e., a *than*-phrase, but the latter may not. Therefore, it is a great problem to represent the comparing and compared arguments in comparative conditionals. Beck's idea is to let the morpheme *the* in charge of this. She suggests that the morpheme *the* can take three arguments as defined in (33). The first argument is a pair of individual, time or world variables, the second argument the comparative morpheme *-er* and the third argument the interpretation of C'. Take (32) for example. The first argument is a

⁷ According to Beck, measure phrases showing difference specification also appear in the specifier position of DegP. Therefore, the morpheme *the* in a comparative conditional is incompatible with a difference phrase.

pair of world variables, which serve as the comparing and compared arguments of the comparative morpheme *-er*. According to this analysis, we obtain the interpretation (34) for (32).

(33) $[[\text{the}']](w_1, w_2)([[\text{-er}']](D_{\langle s, \langle d, t \rangle \rangle}) \text{ iff } \exists d[d > 0 \ \& \ [[\text{-er}']](D(w_1)(d)(D(w_2)))]$

(34) $\forall (\lambda w_1, w_2[\text{the}'(w_1, w_2)(\text{-er}')(\lambda w \lambda d[\text{well}'(d, \lambda x[\text{prepared}'_w(x)])(\text{Otto}))]])$
 $(\lambda w_1, w_2[\text{the}'(w_1, w_2)(\text{-er}')(\lambda w \lambda d[\text{good}'_w(d, \text{Otto}'\text{s_talk})])])$

iff $\forall w_1, w_2[\exists d[d > 0 \ \& \ \text{the max } d_2[\text{well}(d_2, \lambda x[\text{prepared}'_{w_2}(x)])(\text{Otto})] = d + \text{the}$
 $d_1[\text{well}'(d_1, \lambda x[\text{prepared}'_{w_1}(x)])(\text{Otto})]]]$

$\Rightarrow [\exists d'[d' > 0 \ \& \ \text{the max } d_2[\text{good}'_{w_2}(d_2, \text{Otto}'\text{s_talk}')] = d' + \text{the max}$
 $d_1[\text{good}'_{w_1}(d_1, \text{Otto}'\text{s_talk}')]]]$

The meaning that (34) expresses is as follows: For all worlds w_1 and w_2 , the degree of Otto's preparedness is better in w_2 than in w_1 , then the degree of excellence of his talk is better in w_2 than in w_1 .

In (34), the variables quantified over are world variables. If instead (29) is considered, the variables quantified over are individual variables. To save the space, I will no longer illustrate the detailed analysis.

According to Beck, the above proposal of comparative conditionals not only provides semantics for such constructions but also has an immediate syntactic consequence concerning the absence of an overt item of comparison. She points out that though standard comparative constructions allow an overt item of comparison, i.e., a *than*-phrase, to appear as in (35), comparative conditionals do not as the ungrammaticality of (36) shows.

(35) Otto is more tired than Hans.

(36) *The more tired Otto is than Hans, the more aggressive he is.

According to her, examples such as (36) are ill-formed because of the following reason, where *je/umso/desto* are the German counterparts of English *the*:

We get the two elements to be compared with the help of the operator denoted by *je/umso/desto*. This operator allows us to use the information provided by the syntax twice. Thus, to add an item of comparison in the syntax is impossible because we already have one, although one that is not visible as such at S-structure. It is implicitly present with the operator. (Beck 1997: 253)

To put it in another way, if the two compared items are times in (36), (36) is ruled out

because the following paraphrase does not make sense on Beck's proposal: The more tired Otto is at time t_1 than at time t_2 than Hans, the more aggressive he is at time t_1 than at time t_2 .

4. Motivating a New Analysis of Chinese Comparative Correlatives

From the discussion in the last section, it is clear that Beck's analysis of English comparative conditionals relies heavily on the semantic analysis of the morphemes *the* and *-er*, because it is these two morphemes that provide the source of comparison in comparative conditionals. However if we compare Chinese comparative correlatives with English comparative conditionals, we find that it is not that straightforward to directly apply Beck's analysis to Chinese comparative correlatives. On the one hand, Chinese lacks a morpheme equivalent to the English morpheme *the*. On the other hand, it is not clear that *yuè* 'more' is the Chinese counterpart to the English comparative morpheme *-er*, because it does not appear in comparative constructions as illustrated in (37).

- (37) a. Zhāngsān bǐ Lǐsì gāo
Zhangsan compare Lisi tall
'Zhangsan is taller than Lisi.'
b. Zhāngsān bǐjiào gāo
Zhangsan compare tall
'Zhangsan is taller.'

Despite the superficial differences between Chinese comparative correlatives and comparative conditionals in other languages, Beck (1991) suggests in footnote 14 that the function of *the* in comparative conditionals is taken by *yuè* in Chinese comparative correlatives, which also occurs twice just like *the*. If this position is adopted and we further assume that the Mandarin counterpart of *-er* is a phonologically null element, then Chinese comparative correlatives are complete analogues of comparative conditionals in other languages and there will be no problem in applying Beck's semantics of comparative conditionals to Chinese comparative correlatives. Below I will provide two arguments that question this line of thinking.

To begin with, let me point out an interesting fact about the positive form of gradable adjectives in Chinese. The positive form of gradable adjectives in Chinese may not stand alone and need support of the morpheme *hěn* 'very' in order for the sentence containing them to be acceptable. This is illustrated by the contrast between

(38a) and (38b).

- (38) a. *Zhāngsān jiànkāng
Zhangsan healthy
'Zhangsan is healthy.'
b. Zhāngsān hěn jiànkāng
Zhangsan very healthy
'Zhangsan is healthy.'

The use of *hen* 'very' in sentences such as (38b) has been taken as the most neutral 'positive degree marker' (see Sybesma 1999 and *Xidai Hanyu Xuci Lishi* 1982).⁸ I agree with this view. According to Kennedy (2005), there are two possible universal features of the positive form of gradable adjectives. One is the context-dependent interpretations as illustrated by (39) and (40). Whether or not a sentence such as (39) is true depends upon the context in which it is uttered. When the context is about living in various Italian cities, as in (40a), (39) could be judged true. But the same sentence is false in a context like (40b).

(39) The coffee in Rome is expensive.

(40) a. In Rome, even the coffee is expensive.

b. The rents are high in Rome, but at least the coffee is not expensive.

Kennedy suggests that such variability may be accounted for in terms of a "Delineation Function" which "maps a measure function to a degree that represents an appropriate standard of comparison based on features of the context of utterance" (also see Lewis 1970; Graff 2000; Barker 2002; Kennedy and McNally 2005; Kennedy 2005). This "Delineation Function" is denoted by a degree morpheme *pos* as given below:⁹

$$(41) [[pos]]^s = \lambda g \in D_{\langle e,t \rangle} \lambda x. g(x) > s(g)$$

Kennedy speculates that universally the positive form is not expressed by an overt degree morphology, which he takes to be the second possible universal feature of the positive form.

Despite Kennedy's speculation that there is no overt degree morphology

⁸ According to *Xiandai Hanyu Xuci Lishi* (1982), *hěn* is not stressed when functioning as a positive degree marker. When it is stressed, it is interpreted as an intensifier.

⁹ According to Kennedy (2005), instead of assuming a covert degree morpheme *pos*, the same semantics can also be achieved by assuming a lexical type-shifting rule for adjectives.

associated with the positive form of gradable adjective, the obligatory presence of *hěn* in Chinese sentences such as (38b) seems to falsify this speculation. The first piece of evidence for this claim comes from the fact that “*hěn* + Adj” displays exactly the same context-dependent interpretation as the positive form of gradable adjectives in English. Thus, like the positive form *expensive* in (40), the standard of comparison of *hěn* + *qióng* ‘very + poor’ in (42a) and (42b) is different.

- (42) a. tā hěn qióng , lián chī fàn de qián dōu méi yǒu
 he very poor even eat meal Rel money all not have
 ‘He is poor. He even does not have money to eat meals.’
- b. tā hěn qióng , lián jiāochē dōu mǎi-bù-qǐ
 he very poor even sedan all buy-not-afford
 ‘He is poor. He cannot even afford a sedan.’

A second piece of evidence can be adduced by crisp judgments about borderline cases, i.e., objects for which it is unclear whether or not the predicate holds. According to Kennedy (2005), “a feature of the delineation function is that it is constrained to return to a value that counts as a *significant degree* of the relevant property in the context of utterance”. This feature predicts a difference in acceptability when the context involves very slight differences between the compared objects. For example, in the context of (43A), both the explicit and implicit comparison is acceptable, but in the context of (43B), the positive form, i.e., the implicit comparison, is not acceptable.

- (43) CONTEXT A: A 600 word essay and a 200 word essay
 a. This essay is longer than that one.
 b. Compared to that essay, this one is long.
- CONTEXT B: A 600 word essay and a 590 word essay
 a. This essay is longer than that one.
 b. ??Compared to that essay, this one is long.

Significantly, the Chinese sentence below is also unacceptable in the context of (43B) but acceptable in the context of (43A).

- (44) Gēn nà-piān wénzhāng bǐ qǐ-lái , zhè-piān wénzhāng * (hěn) cháng
 with that-Cl article compare getting this-Cl article very long
 ‘Compared to that article, this article is long.’

The above fact indicates that *hěn* in Chinese is indeed an overt comparison degree morphology that expresses the “Delineation Function”.

In addition to *hěn*, there are other degree comparison morphemes such as *gèng* ‘more’ or its variant *gèngjiā* and *bǐjiào* ‘more’ or its variant *jiàowéi*, as the following sentences illustrate.

- (45) Gēn Zhāngsān bǐ qǐlái , Lǐsì bǐjiào xiǎoqì
 with Zhangsan compare getting Lisi more stingy
 ‘Compared to Zhangsan, Lisi is stingier.’
- (46) Gēn Zhāngsān bǐ qǐlái , Lǐsì gèng xiǎoqì
 with Zhangsan compare getting Lisi more stingy
 ‘Compared to Zhangsan, Lisi is stingier, (though both are stingy).’

The meaning of *bǐjiào* ‘compare’ in (45) is much close to the English comparison morpheme *-er*. (45) is true as long as Lisi is stingier than Zhangsan but Zhangsan does not have to be stingy. In contrast, for (46) to be true, both Zhangsan and Lisi must be stingy according to the standard of comparison and furthermore Lisi is stingier than Zhangsan.

Above we saw that Chinese has different degree morphemes that compare two objects or compare one object and a contextual standard of comparison and says that one object has a higher degree than the other object or the contextual standard with respect to the property denoted by the adjective. Significantly, these different degree comparison morphemes may not occur with each other. Thus, the following sentences are all ill-formed regardless of the word order of the degree comparison morphemes.

- (47) a. *Gēn Zhāngsān bǐ qǐlái , Lǐsì hěn bǐjiào/bǐjiào hěn xiǎoqì
 with Zhangsan compare getting Lisi very more/more very stingy
 ‘Compared to Zhangsan, Lisi is much stingier.’
- b. *Gēn Zhāngsān bǐ qǐlái , Lǐsì hěn gèng/gèng hěn xiǎoqì
 with Zhangsan compare getting Lisi very more/more very stingy
 ‘Compared to Zhangsan, Lisi is much stingier, (though both are stingy).’
- c. *Gēn Zhāngsān bǐ qǐlái , Lǐsì gèng bǐjiào/bǐjiào gèng xiǎoqì
 with Zhangsan compare getting Lisi more more/more more stingy
 ‘Compared to Zhangsan, Lisi is much stingier.’

Returning to the Chinese comparative correlatives, we find that the morpheme *yuè* may not occur with other degree comparison morphemes, as is shown by (48).

- (48) *Pingguǒ yuè hěn/gèng/bǐjiào dà , ……
 apple YUE very/more/more big
 ‘lit. The bigger an apple is (than another one which is also big),…’

The easiest way to account for the unacceptability of (48) that I can imagine is to assume that *yuè* itself is a degree comparison morpheme just like *hěn*, *gèng* and *bǐjiào*. Therefore, the unacceptability of (48) simply falls under the same generalization as the sentences in (47); namely, one sentence does not allow two degree comparison morphemes. In contrast, if we assume that *yuè* is an equivalent to the English morpheme *the* as Beck has suggested and the comparative correlatives in Chinese involve a null *-er*, at least two difficult problems arise. The first one is that the ungrammaticality of (48) will immediately become a puzzle, because we can no longer explain the ill-formedness of (48) in the same way as we account for the unacceptability of the examples in (47). The second problem is that Beck’s proposal raises the question of why the null comparison degree morpheme is unlike the other overt comparison degree morphemes with respect to the compatibility with *yuè*. In view of these problems, I conclude that the treatment of *yuè* as a counterpart to English *the* and the postulation of a null *-er* for Chinese comparative correlatives raise more questions than treating *yuè* itself as a comparison degree morpheme as I will argue later.

A second problem with Beck’s suggestion to extend her analysis of comparative conditionals to Chinese comparative correlatives is related to the co-occurrence problem between *the* (or its equivalents in other languages) and an overt item of comparison. As noted, one property of comparative conditionals in English is the incompatibility between the morpheme *the* and an overt item of comparison as we saw in (49), reproduced below.

- (49) *The more tired Otto is than Hans, the more aggressive he is.

Recall that Beck’s explanation of this is that a *than*-phrase is impossible in comparative conditionals because an overt item of comparison is already implicitly present in the semantics, i.e, the pair of variables that serve as the first argument of *the*. Now if Chinese *yuè* did take the job of *the* and had the same semantics as *the* as Beck has suggested in her footnote, the prediction would be that *yuè* is incompatible with an overt item of comparison. Unfortunately, this prediction is not born out. In Chinese, *yuè* may naturally occur with an overt item of comparison, as McCawley (1988: 183) and Liu (2006) have already pointed out. One example to illustrate is

(50).

(50) nǐ yuè bǐ tā kuàilè , tā jiù yuè tongkǔ
you more compare he happy he then more painful
'lit. *The happier you are than he, the more painful he is.'
'The more your happiness exceeds his,, the more painful it is for him.'

(50) clearly indicates that Beck's suggested treatment of *yuè* in Chinese as the equivalent of *the* in English is problematic, because the semantics of *the* that she has proposed wrongly exclude examples such as (50). *Yuè* is actually an adverb adjoined to VP, indicating an increasing degree of the property denoted by VP/AP. It alone should be responsible for what *the* and *-er* together do in English comparative conditionals; namely, in Chinese comparative correlatives, *yuè* alone should undertake the responsibility of providing the two items that are compared.

Above we have seen that there are difficulties in adopting Beck's suggested treatment of *yuè* as the Chinese equivalent of English *the* and assuming a null *-er* in Chinese. It is also suggested that *yuè* alone should be responsible for what *the* and *-er* together do in English comparative conditionals. In what follows, I will show that a possible modification of Beck's analysis in which the meanings of *the* and *-er* are collapsed, as one reviewer has suggested to me, encounters the same problem.

Let us assume that *the* in English is semantically vacuous and that the comparative morpheme *-er* in English has a meaning as in (51), which collapses the functions of the original *the* and *-er* and get truth conditions equivalent to the ones originally derived.

(51) $[[\text{-er}]](w_1, w_2)([[D_{\langle s, \langle d, t \rangle} \rangle]])$ iff
 $\exists d[d > 0 \ \& \ \max(\lambda d.D(w_1)(d)) = d + \max(\lambda d.D(w_2)(d))]$

This proposal makes it sound more likely to identify the meaning of *yuè* in Chinese as *-er* in English.

The problem with the above modification of Beck's original proposal is that just like the original proposal, the semantics in (51) excludes an overt item of comparison from being present, because items of comparison are already given by the semantics of *-er*. Therefore, we cannot say that *yuè* in Chinese has the same semantics as *-er* in (51).

In addition, the proposal of (51) has its cost as the reviewer has pointed out to me; namely,

- (i) We can no longer keep the meaning of the comparative morpheme uniform in different comparative constructions, for instance, the *-er* in standard comparatives is different from the *-er* in comparative conditionals.
- (ii) The modification will lose Beck's original account for the impossibility for comparative conditionals to include measure phrases.
- (iii) German data like (52) discussed by Beck (1997: 254) implies semantic contribution of *umso*, the German equivalent of English *the*.

(52) Gestern war es kühl. Heute ist es umso heißer
 Yesterday was it cool. Today is it the hotter
 'It was cool yesterday. Today it's all the more hot.'

So it seems that if we want to keep the spirit of Beck's proposal, there will be no easy way to unify Chinese comparative correlatives and English comparative conditionals or their counterparts in other languages. In fact, I doubt that this is possible. Therefore, in what follows, I will try to do things the other way around. I will first provide a semantics of *yuè* as occurs in Chinese comparative correlatives and then explore the possibility of extending the proposed analysis of *yuè* to English *-er* as occurs in "the Adj-*er*...the Adj-*er*..." constructions. Meanwhile, a novel proposal of the function of *the* will be made which is capable of explaining why it is incompatible with an overt item of comparison.

5. A Proposal of Chinese Comparative Correlatives

Before analyzing the Chinese comparative correlatives in detail, I would like to first make some of my general assumptions clear. As noted, according to Heim (1982) and Lewis (1975), the semantics of conditionals involve quantificational structure. I will adopt this approach to Chinese comparative correlatives, too, because we find the same shared similarities between Chinese comparative correlatives and regular conditionals as Beck has observed between English comparative conditionals and regular conditionals. Apart from this, it is helpful to explain von Stechow's (1994) use of extension relation in conditionals. According to von Stechow (1994), the meaning of a proposition refers to those situations in which the proposition is true and situations have minimal situations. Adverbs of quantification in conditionals may quantify over minimal situations. Under this assumption, the meaning of "Qadv, if P, Q" is roughly as follows:

(53) $[[Q_{adv}]](P)(Q) = Q_{adv} s_{min} [P \text{ is true in } s] [\exists s' [s \leq s' \ \& \ Q \text{ is true in } s']]$

What (53) says is this: For Q_{adv} minimal situations in which P is true, there is an extension from s to s' such that Q is true in s' . A few remarks on the notion of extension are in order here. According to von Stechow, under the notion of minimal situations, if P -situation is a minimal situation, then it is not possible that the minimal P -situation is also a Q situation. Therefore, the notion of extension is necessary in the semantics of conditionals.

The use of the notion of “extension” has another important role to play in (53). According to Kratzer (1998), natural language does not allow vacuous quantification, whose definition is given in (54).

(54) Prohibition Against Vacuous Quantification

For every Quantifier Q , if Q quantifies over/binds a variable in the restrictive clause, then it must quantify over/bind another occurrence of the same variable in the nuclear scope and vice versa.

In (53) the use of extension provides the situation variable s in the nuclear scope so that the quantifier Q_{adv} may bind one occurrence of s in the restrictive clause and another occurrence in the nuclear scope.

Another assumption that I adopt is that adjectives have an additional degree argument and verbs also have an additional degree or quantity argument. It is not controversial to assume that adjectives have a degree argument¹⁰, but the assumption that verbs have a degree or quantity argument is less heard of. Here, I am following Doetjes (1997), who argues for an extra degree or quantity position on the basis of the distribution of degree adverbs in French, Dutch and English. Doetjes’s (1997) has argued that the degree position of a predicate is dependent on the event position. In this paper, I will also follow this assumption but use situation variables instead of event variables. I will use the variable g to represent a verb’s degree or quantity argument without distinguishing them. Both have the semantic type d , which is reminiscent of the word *degree*. On this assumption, an adjective like *gāoxìng* ‘happy’ or a verb like *zǒu* ‘walk’ denotes $\lambda x \lambda g \lambda s. walk(x)(g)(s)$ of semantic type of $\langle e, \langle d, \langle s, t \rangle \rangle \rangle$, where $walk(x)(g)(s)$ means that x has done a g -quantity of walking in situation s .

Thirdly, I assume that in “*yuè... yuè...*” constructions the first clause is mapped to the restriction of a possibly covert quantifier and the second clause to the

¹⁰ For instance, see Cresswell (1976), von Stechow (1984), Heim (2001), among others.

nuclear scope.¹¹ Moreover, just as the morphemes *the* and *-er* under Beck’s analysis of comparative conditionals take scope over the restriction and nuclear scope, the two *yuè*’s are adjoined to the restriction and the nuclear scope, respectively, in logical form and the possibly empty *jiù* is adjoined to the top of the nuclear scope.

Given the above assumptions, I am now in a position to analyze Chinese comparative correlatives. Take (1), reproduced below, for instance. Its logical form looks like (55).

- (1) nǐ yuè shēngqì , tā (jiù) yuè gāoxìng
 you more angry he then more happy
 ‘The more angry you are, the happier he is.’

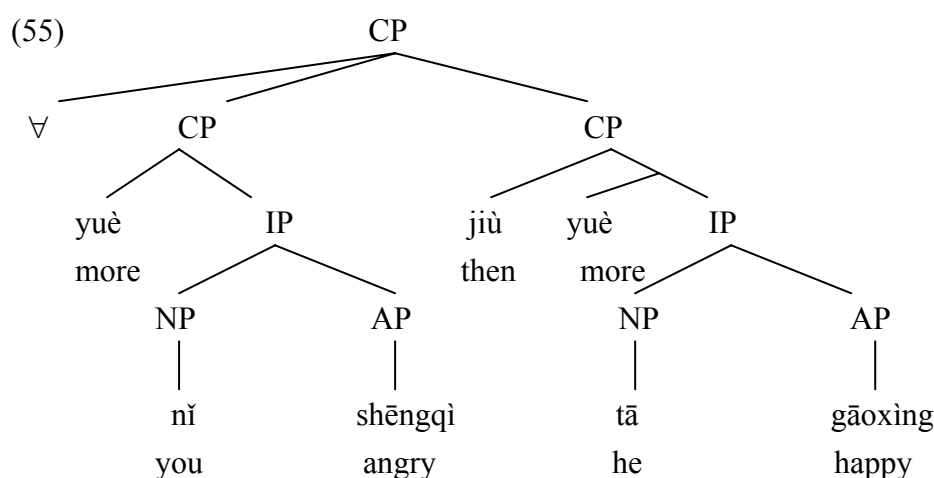

In addition to the above logical form, two other important things in analyzing the Chinese “*yuè... yuè...*” constructions” are the semantics of *yuè* and *jiù*. I propose that *yuè* is a degree adverb whose main semantic function, in its simplest case, is to compare two degree arguments and claim that one degree in situation s_1 is greater than the other degree in situation s_2 . That is, in the simplest case, the argument of *yuè* is properties of a relation between a degree and a situation with the form $\lambda g \lambda s.P(g)(s)$ of type $\langle d, \langle s, t \rangle \rangle$. When *yuè* takes such an argument, the $\langle d, \langle s, t \rangle \rangle$ expression in question will apply to a different degree and situation variable twice, producing two propositions and claiming that one degree in a situation is greater than the other degree in another situation, as is shown in (56).

$$(56) [[yuè]] = \lambda P_{\langle d, \langle s, t \rangle \rangle} \lambda g_1 \lambda g_2 \lambda s_1 \lambda s_2 [P(g_1)(s_1) \wedge P(g_2)(s_2) \wedge g_2 > g_1]$$

However, the argument of *yuè* is not always properties of a relation between a

¹¹ Liu (2006) has made a similar suggestion for comparative correlatives. However, his discussion of the semantics of comparative correlatives remain descriptive and informal. So in this paper I will not make substantial comments on this unpublished conference presentation.

degree argument and a situation. It can also be a relation between individuals, degrees, and situations i.e., an expression of type $\langle e, \langle d, \langle s, t \rangle \rangle \rangle$. In such a case, the semantics of *yuè* requires that the $\langle e, \langle d, \langle s, t \rangle \rangle \rangle$ expression applies to two different individuals, two different degrees and two different situations, again producing two propositions and claiming that one degree of a given property of the first individual in a situation is greater than the other degree of the same given property of another individual in another situation. This is illustrated in (57).

$$(57) [[yuè]] = \lambda P_{\langle e, \langle d, \langle s, t \rangle \rangle} . \lambda x \lambda y \lambda g_1 \lambda g_2 \lambda s_1 \lambda s_2 [P(x)(s_1) \wedge P(y)(s_2) \wedge g_2 > g_1]$$

In other words, the argument of *yuè* actually does not have a fixed semantic type but a flexible one.

Despite the flexibility of the semantic type of the argument of *yuè*, the different cases can be unified under one single generalization as proposed in (55), where each α stands for a semantic type.

$$(58) [[yuè]] \\ = \lambda P_{\langle \alpha_1, \langle \dots \langle d, \dots \langle \alpha_n, \langle s, t \rangle \rangle \rangle \rangle \rangle} \lambda \alpha_1' \lambda \alpha_1'' \dots \lambda d_1 \lambda d_2 \dots \lambda \alpha_n' \lambda \alpha_n'' \lambda s_1 \lambda s_2 [P(\alpha_1') \dots (d_1) \dots (\alpha_n')(s_1) \wedge \\ P(\alpha_1'') \dots (d_2) \dots (\alpha_n'')(s_2) \wedge d_2 > d_1]$$

As for the word *jiù*, to understand its function in a sentence, let us consider more contexts in which it occurs:

- (59) a. *rúguǒ xiàyǔ , wǒ jiù bú qù*
 if rain I JIU not go
 ‘If it rains, then I will not go.’
- b. *yīnwèi xiàyǔ , suǒyǐ wǒ jiù méi qù shàng kè*
 because rain so I JIU not go attend class
 ‘Because it rained, I therefore didn’t go to the class.’
- c. *zhǐyào nǐ qù , wǒ jiù qù*
 as-long-as you go I JIU go
 ‘As long as you go, I will go.’
- d. *wǒ cái gāng dào , tā jiù yào zǒu*
 I CAI just-now arrive he JIU want leave
 ‘As soon as I just arrived, he wanted to leave.’
- f. *cóng dì yī cì jiànmiàn , wǒ jiù xǐhuān tā*
 from the first time meet I JIU like him
 ‘I have liked him since I met him for the first time.’

All the examples above seem to have a causation flavor with varying degrees. The causation flavor is apparent in the first three sentences in (59) but less obvious in (59d) and (59f). In (59d), my arriving can be interpreted as the cause of his leaving, perhaps because he does not like me.¹² As for (59f), let us imagine a context like the following.

Mary met John in a conference. He is a man of great learning and is very handsome. Since their meeting in the conference, Mary has liked John.

In the above context, it is hard to say that the meeting event itself causes Mary to like John. Instead, it is John's appearance and his knowledge that impressed Mary and made her like him. This example is a good case showing that it is not necessarily the case that when two events e_1 and e_2 are linked by *jiù*, e_1 must directly cause e_2 . It can be the case that properties of participants of e_1 cause the occurrence of e_2 . Nevertheless, a certain relation, which might be pragmatically determined, still must hold between e_1 and e_2 in order to make it possible for properties of the participant of the event to trigger the causation. I think that the obvious cases of causation as witnessed by (59a-c) should be analyzed the same way, namely, the causation flavor should be derived from the relation that *jiù* conveys. Although I will not be specific about the content of this relation because I do not know exactly how to pin it down, I will refer to this relation as relation *R*, from which the causation flavor is derived.

I believe that the *jiù* as occurs in Chinese comparative correlatives is the same *jiù* as occurs in (59). Thus, comparative correlatives have the same kind of causation flavor as the examples in (59). This causation meaning explains why the examples in (60), as opposed to those in (61), are not acceptable sentences.¹³ (60a) sounds odd, because it is impossible for there to be a causal relation (at least in the actual world) between *Zhangsan's* scolding *Lisi* and *Lisi's* growing tall.¹⁴ Similarly, (60b) is

¹² (59d) can also be interpreted in such a way that it's an accident that his leaving is close to my arriving. On this reading, it's the short distance between two time intervals that is behind the relation of the two propositions involved. It is not clear to me whether this interpretation of *jiù* is the same *jiù* as occurs in (59a-c), because *jiù* clearly also has a non-causation meaning as the examples in (i). It is difficult to pin down what *jiù* in the examples in (i) below means and I will not try to discuss this issue.

- (i) a. sān ge jiù gòu le
 three Cl JIU enough Par
 'Three is enough.'
 b. tā bā diǎn jiù dào le
 he eight o'clock JIU arrive Par
 'He arrived as early as eight o'clock.'

¹³ A reviewer asks why the two examples in (60) remain ungrammatical if *jiù* is taken out. I assume that when the overt *jiù* does not surface, the construction still contains an implicit equivalent of *jiù*. Therefore, the causation flavor is always there, no matter whether *jiù* surfaces in syntax.

¹⁴ The analysis predicts that examples like (60) in fantasy contexts should become acceptable when the causal relation is forced. This is indeed the case. Suppose that the context of *Alice in Wonderland* is (i),

unacceptable, because normally a person's mental activity has no causal relation to the change of weather. In contrast, the examples in (61) are all acceptable because in each case a reasonable causal relation can be established between the first and the second clause.

- (60) a. *Zhāngsān yuè mà , Lǐsì jiù yuè gāo
 Zhangsan more scold Lisi then more tall
 'The more Zhangsan scolded (Lisi), the taller Lisi is.'
- b. *wǒ xiǎng zhèi ge wèntí yuè jiǔ , yǔ jiù xià de
 I think this Cl question more long rain then fall DE
 yuè dà
 more heavy
 'The more I think about this question, the heavier the rain is.'
- (61) a. Zhāngsān yuè mà , Lǐsì jiù yuè bù lǐ tā
 Zhangsan more scold Lisi then more not pay-attention-to him
 'The more Zhangsan scolds Lisi, the more Lisi does not want to pay attention to him.'
- b. wǒ xiǎng zhèi ge wèntí yuè jiǔ , xīnqíng jiù yuè
 I think this Cl question more long mood then more
 jǔsàng
 depressed
 'The more I think about this question, the more depressed I feel.'
- c. wūyún yuè duō , yǔ jiù xià de yuè dà
 dark-cloud more many rain then fall DE more heavy
 'The more dark clouds the sky has, the heavier the rain will be.'

In view of data like those in (60)-(61), I propose that *jiù* in Chinese comparative correlatives links the degree arguments in the first and second clause through a relation R from which the causation flavor is derived. To be more precise, I propose that a “*yuè... (jiù) yuè...*” construction as a whole has a syncategorematic meaning as in (62), which put the causality into the meaning of the construction through the pragmatically determined relation R:¹⁵

where the scolding of the rabbit is a certain kind of spell which causes the person being scolded by the rabbit to become taller for each scolding. Then the Chinese comparative correlative in (ii) is indeed acceptable.

- (i) The more the rabbit scolded Alice, the taller she became.
 (ii) Tùzi yuè mà àilǐsī , àilǐsī jiù biàn de yuè gāo
 rabbit more scold Alice Alice then become DE more tall
 'The more the rabbit scolded Alice, the taller Alice becomes.'

¹⁵ For the sake of simplicity, I have treated *jiù* as a syncategorematic item without its own semantic

$$(62) \text{ [[Qadv]](yuè -P)(jiù yuè -Q)}^{16}$$

$$= \text{Qadv } \alpha_1', \alpha_1'' \dots d_1, d_2 \dots \alpha_n', \alpha_n'', s_1, s_2 [P(\alpha_1') \dots (d_1) \dots (\alpha_n')(s_1) \wedge$$

$$P(\alpha_1'') \dots (d_2) \dots (\alpha_n'')(s_2) \wedge d_2 > d_1] [\exists d_3, d_4, s_3, s_4 [s_1 \leq s_3 \wedge s_2 \leq s_4 \wedge R(\langle d_1, s_1 \rangle, \langle d_3, s_3 \rangle) \wedge$$

$$R(\langle d_2, s_2 \rangle, \langle d_4, s_4 \rangle) \wedge Q(\alpha_1') \dots (d_3) \dots (\alpha_n')(s_3) \wedge Q(\alpha_1'') \dots (d_4) \dots (\alpha_n'')(s_4) \wedge d_4 > d_3]]$$

In (62), the condition ‘ $R(\langle d_1, s_1 \rangle, \langle d_3, s_3 \rangle)$ ’ is intended to mean that the degree d_1 in the situation s_1 has a relation R to the degree d_3 in the situation s_3 . Since the relation R may give rise to a causation meaning, the meaning is obtained that the degree d_1 in the situation s_1 has caused the degree d_3 in the situation s_3 .

To illustrate the application of (62), reconsider (1), reproduced below. According to the semantic rules discussed above, the step-by-step computation of (1) is (63).

(1) nǐ yuè shēngqì , tā (jiù) yuè gāoxìng
 you more angry he JIU more happy
 ‘The angrier you are, the happier he is.’

$$(63) \text{ a. [[}_{AP} \text{shēngqì}]] = \lambda x \lambda g \lambda s. \text{angry}'(x)(g)(s)$$

$$\text{ b. [[}_{IP} \text{nǐ shēngqì}]] = \lambda g \lambda s. \text{angry}'(\text{you}') (g)(s)$$

$$\text{ c. [[}_{CP} \text{yuè nǐ shēngqì}]]$$

$$= \lambda P_{\langle d, \langle s, t \rangle \rangle} \lambda g_1 \lambda g_2 \lambda s_1 \lambda s_2 [P(g_1)(s_1) \wedge P(g_2)(s_2) \wedge$$

$$g_2 > g_1] (\lambda g \lambda s. \text{angry}'(\text{you}') (g)(s))$$

$$= \lambda g_1 \lambda g_2 \lambda s_1 \lambda s_2 [\text{angry}'(\text{you}') (g_1)(s_1) \wedge \text{angry}'(\text{you}') (g_2)(s_2) \wedge g_2 > g_1]$$

$$\text{ d. [[}_{CP} \text{yuè tā gāoxìng}]] = \lambda g_3 \lambda g_4 \lambda s_3 \lambda s_4 [\text{happy}'(\text{he}') (g_3)(s_3) \wedge \text{happy}'(\text{he}') (g_4)(s_4)$$

$$\wedge g_4 > g_3]$$

$$\text{ e. [[}_{\forall} \text{yuè nǐ shēngqì jiù yuè tā gāoxìng}]]$$

$$= \forall g_1, g_2, s_1, s_2 [\text{angry}'(\text{you}') (g_1)(s_1) \wedge \text{angry}'(\text{you}') (g_2)(s_2) \wedge g_2 > g_1]$$

$$\Rightarrow \exists g_3 \exists g_4, s_3, s_4 [s_1 \leq s_3 \wedge s_2 \leq s_4 \wedge R(\langle g_1, s_1 \rangle, \langle g_3, s_3 \rangle) \wedge R(\langle g_2, s_2 \rangle, \langle g_4, s_4 \rangle) \wedge$$

$$\text{happy}'(\text{he}') (g_3)(s_3) \wedge \text{happy}'(\text{he}') (g_4)(s_4) \wedge g_4 > g_3]$$

What (63) says is this: For every g_1, g_2, s_1, s_2 such that you are g_1 -degree angry in s_1 and g_2 -degree angry in s_2 , and g_2 is greater than g_1 , there exist a g_3, g_4, s_3 and s_4 such that

value. It is possible to assign *jiù* an independent meaning as in (i).

$$(i) \text{ [[}_{jiù}]] = \lambda \wp_{\langle \alpha_1', \langle \alpha_1'' \dots \langle d_1, \langle d_2 \dots \langle \alpha_n', \langle \alpha_n'' \dots \langle s_1, \langle s_2 \dots \langle s_t \dots \rangle \rangle \rangle \rangle \rangle \rangle \rangle} \lambda \wp_{\langle \alpha_1', \langle \alpha_1'' \dots \langle d_3, \langle d_4 \dots \langle \alpha_n', \langle \alpha_n'' \dots \langle s_3, \langle s_4 \dots \rangle \rangle \rangle \rangle \rangle \rangle} [[\wp(x_1')$$

$$(x_1'') \dots (g_1) (g_2) \dots (x_n') (x_n'')(s_1)(s_2)] \rightarrow [\exists d_3, d_4, s_3, s_4 [s_1 \leq s_3 \wedge s_2 \leq s_4 \wedge R(\langle g_1, s_1 \rangle, \langle g_3, s_3 \rangle) \wedge$$

$$R(\langle g_2, s_2 \rangle, \langle g_4, s_4 \rangle) \wedge \wp(x_1') (x_1'') \dots (g_3) (g_4) \dots (x_n') (x_n'')(s_3)(s_4)]$$

¹⁶ As in von Stechow semantics in (45), I assume that the situations quantified over in (62) are minimal situations.

s_3 is an extended situation of s_1 and s_4 an extended situation of s_2 and he is g_3 -degree happy in s_3 and g_4 -degree happy in s_4 and g_4 is greater than g_3 . Moreover, g_1 in s_1 has an R relation to g_3 in s_3 and g_2 in s_2 an R relation to g_4 in s_4 . The R relation is supposed to derive the causation meaning of the sentence.

A great advantage of the above semantics is that it captures the corresponding or resulting relation between the degree arguments in the first and second clause. This corresponding or resulting relation is expressed via the suggested relation R . This analysis is thus immune from the criticisms that Beck's (1997) analysis suffers from as she has discussed in her paper.¹⁷

Before further analyzing Chinese comparative correlatives, let me discuss one worry that a reviewer has raised about the notion of causation used here and universal quantification over degrees. Suppose that we have a context like (64a) below and the Chinese counterpart to (64b) is (65a). On the proposed analysis of *yuè*, the truth conditions of (65a) is roughly (65b).

(64) a. When we only have one special offer in our store, no retired people come to shop here, they prefer stores that offer considerably more deals. But when we have at least 5, they start coming. When we have more than 5 offers, retirees come in lots.

b. The more special offers we have, the more retirees come to shop here.

(65) a. wǒmén tígōng yuè duō tèjiàpǐn , jiù huì yǒu yuè duō
we provide more many deal then will have more many
tuìxiūrényuán lái zhèlǐ gòuwù
retirees come here shop

‘The more special offers we have, the more retirees come to shop here.’

b. $\forall g_1, g_2, s_1, s_2$ [we have g_1 -many special offers in s_1 & we have g_2 -many special offers in s_2 and $g_2 > g_1$]

\Rightarrow

$\exists g_3 \exists g_4, s_3, s_4$ [$s_1 \leq s_3 \wedge s_2 \leq s_4 \wedge R(\langle g_1, s_1 \rangle, \langle g_3, s_3 \rangle) \wedge R(\langle g_2, s_2 \rangle, \langle g_4, s_4 \rangle)$ & g_3 -many retirees come to shop here in s_3 & g_4 -many retirees come to shop here in s_4 & $g_4 > g_3$]

¹⁷ Beck (1997: 245) writes:

“Many people I have presented this to have complained that this is too weak. The suggestion is that (15) means something like: if there is a positive difference in how well Otto is prepared in w_1 vs. w_2 , then there must also be a corresponding or resulting positive difference in the quality of his presentation in w_1 vs. w_2 . So, the two difference degrees (the one in the antecedent clause and the one in the consequent) should somehow be related: Either they ought to be identical, or proportional, or the second should be functionally dependent on the first.”

Beck has presented an argument against the above criticism. However, in this paper, I will not discuss her argument in detail. Interested readers are referred to the paper directly.

The reviewer says that (65a) is wrongly predicted to be false in the context of (64a), because there is no degree g_3 that was caused by g_1 for $4 \geq g_1 \geq 1$. I believe that this problem is not a serious one, because it is arguably another instance of an old problem related to domain restriction of quantification. The domain restriction of quantification can be illustrated by an English sentence such as *Every student went to the party*. Here, the universal determiner quantifies over the domain of students. However, in order for the sentence in question to be true, it need not be the case that all the students in the whole world went to the party. It is only those students which are relevant, for example those students in my department, that count. A student who does not belong to my department and who didn't go to the party is not able to falsify the universal statement. So natural language quantification often involves an implicit restriction of the domain of quantification and (65a) is no exception.¹⁸ If this is correct, then the problem that the reviewer has raised can be accounted for along this line; namely, those g_1 's such that $4 \geq g_1 \geq 1$ are irrelevant degrees that are not in the domain of restriction. In what follows, I will ignore the issue of implicit domain restriction in order to simplify the proposed analysis which is already very complicated.

To further support the semantics of *yuè* in (58), let us consider (66) in which time can be taken to play a role. Let us suppose that stage-level predicates such as *rè* 'hot' and *bùshūfú* 'uncomfortable' have a time argument in addition to the individual and degree argument. Then the truth conditions of (66) are computed as in (67).

(66) Tiānqì yuè rè , wǒ jiù yuè bùshūfú
 weather more hot I then more uncomfortable
 'The hotter the weather is, the more uncomfortable I feel.'

- (67) a. $[[_{AP} r\grave{e}]] = \lambda x \lambda g \lambda t \lambda s. hot'(x)(g)(t)(s)$
 b. $[[_{IP} ti\grave{a}nq\grave{i} r\grave{e}]] = \lambda g \lambda t \lambda s. hot'(\text{the-weather}')(g)(t)(s)$
 c. $[[_{CP} yu\grave{e} ti\grave{a}nq\grave{i} r\grave{e}]]$
 $= \lambda P_{\langle d, \langle i, \langle s, t \rangle \rangle \rangle} \lambda g_1 \lambda g_2 \lambda t_1 \lambda t_2 \lambda s_1 \lambda s_2 [P(g_1)(t_1)(s_1) \wedge P(g_2)(t_2)(s_2) \wedge g_2 > g_1]$
 $(\lambda g \lambda t \lambda s. hot'(\text{the-weather}')(g)(t)(s))$
 $= \lambda g_1 \lambda g_2 \lambda t_1 \lambda t_2 \lambda s_1 \lambda s_2 [hot'(\text{the-weather}')(g_1)(t_1)(s_1) \wedge$
 $hot'(\text{the-weather}')(g_2)(t_2)(s_2) \wedge g_2 > g_1]$
 d. $[[[_{CP} yu\grave{e} w\check{o} b\grave{u}sh\check{u}f\acute{u}]]]$
 $= \lambda g_3 \lambda g_4 \lambda t_1 \lambda t_2 \lambda s_3 \lambda s_4 [uncomfortable'(I')(g_3)(t_1)(s_3) \wedge$
 $uncomfortable'(I')(g_4)(t_2)(s_4) \wedge g_4 > g_3]$
 e. $[[\forall yu\grave{e} ti\grave{a} q\grave{i} r\grave{e} ji\grave{u} yu\grave{e} w\check{o} b\grave{u}sh\check{u}f\acute{u}]]]$

¹⁸ For a detailed discussion of this issue, the reader is referred to von Stechow (1994).

$$\begin{aligned}
&= \forall g_1, g_2, t_1, t_2, s_1, s_2 [\text{hot}'(\text{the-weather}')(g_1)(t_1)(s_1) \wedge \\
&\quad \text{hot}'(\text{the-weather}')(g_2)(t_2)(s_2) \wedge g_2 > g_1] \\
\Rightarrow &\quad \exists g_3 \exists g_4, s_3, s_4 [s_1 \leq s_3 \wedge s_2 \leq s_4 \wedge R(\langle g_1, s_1 \rangle, \langle g_3, s_3 \rangle) \wedge R(\langle g_2, s_2 \rangle, \langle g_4, s_4 \rangle) \wedge \\
&\quad \text{uncomfortable}'(I')(g_3)(t_1)(s_3) \wedge \text{uncomfortable}'(I')(g_4)(t_2)(s_4) \wedge g_4 > g_3]
\end{aligned}$$

(For every degree g_1, g_2 , time t_1 and t_2 and situation s_1, s_2 , if the weather is g_1 -degree hot at t_1 in s_1 and the weather is g_2 -degree hot at t_2 in s_2 and g_2 is greater than g_1 , then the g_1 -degree hotness at t_1 in s_1 will cause me to feel g_3 -degree uncomfortable at t_1 in s_3 , an extended situation of s_1 and the g_2 -degree hotness will cause me to feel g_4 -degree uncomfortable at t_2 in s_4 , an extended situation of s_2 , and g_4 is greater than g_3 .)

As the reader can check by himself/herself, the truth conditions given in (67), where the degree of hotness is relative to a given time and situation seems to be intuitively correct for the sentence in (66). In particular, the truth conditions do not require that the degree of hotness increases with the advance of time. For example, the truth conditions in (67) predict that it is possible for (66) to be used in a scenario like the following: The degree of hotness at a time t_1 is greater than the degree of hotness at a time t_2 , and t_2 follows t_1 and I am more uncomfortable at t_1 than at t_2 . This further supports the proposed analysis of *yuè*.

Above I have shown how degree arguments can be compared with respect to a time and a situation. However, as noted by Beck for English comparative conditionals, it is possible to compare two different individuals with respect to the degree of a given property, too. For instance, according to her analysis, the semantic paraphrase of (68a) should be (68b).

- (68) a. The bigger an apple is, the more delicious it is.
b. $\forall x, y [\text{apple}'(x) \wedge \text{apple}'(y) \wedge x \text{ is bigger than } y] [x \text{ is more delicious than } y]$

Now the question is: Do we get the same paraphrase for the Chinese counterpart to (68a)? The answer seems to be yes as (69) shows. (69) has a reading on which we compare the degrees of bigness and deliciousness of different apples.

- (69) pingguǒ yuè dà , (jiù) yuè hǎochī
apple more big then more delicious
‘The bigger an apple is, the more delicious it is.’

Given this reading, the next task is to explain how such a reading comes about.

I begin by discussing the interpretation of common nouns. As is well-known, the most basic interpretation of common nouns is the $\langle e, t \rangle$ interpretation. In (69), the subject NP consists of the bare common noun *pingguǒ* ‘apple’ only. Suppose that the $\langle e, t \rangle$ interpretation of this bare common noun percolates to the subject NP. Apparently, this meaning of the subject NP is not able to be combined with the meaning of the VP of type $\langle e, \langle d, \langle s, t \rangle \rangle \rangle$ via functional application. Although $\langle e, t \rangle$ and $\langle e, \langle d, \langle s, t \rangle \rangle \rangle$ do not combine via functional application, they may get an interpretation via the following interpretation rule:¹⁹

(70) If a noun phrase translates as $\lambda x[N(x)]$ and a predicate AP translates as $\lambda x \lambda g \lambda s. AP(x)(g)(s)$, then $[[NP AP]]$ translates as $\lambda x \lambda g \lambda s [N(x) \wedge AP(x)(g)(s)]$.

According to (70) and the semantics of *yuè*, the first clause of (69) should then translate as (71):

(71) a. $[[pingguǒ dà]] = \lambda x \lambda g \lambda s [apple'(x) \wedge big'(x)(g)(s)]$
 b. $[[yuè pingguǒ dà]]$
 $= \lambda x \lambda y \lambda g_1 \lambda g_2 \lambda s_1 \lambda s_2 [apple'(x) \wedge big'(x)(g_1)(s_1) \wedge apple(y) \wedge big'(y)(g_2)(s_2) \wedge g_2 > g_1]$

As for the second clause in (69), the subject NP is an empty NP. I propose that in Chinese “*yuè... yuè...*” constructions, such empty subject NPs, indicated by a cross-out line, copy their interpretation from the subject NP in the first clause.²⁰ Therefore, the meaning of the second clause in (69) without *jiù* is (72).

(72) $[[yuè \text{—} pingguǒ hǎo chī]]$
 $= \lambda x \lambda y \lambda g_3 \lambda g_4 \lambda s_3 \lambda s_4 [apple'(x) \wedge delicious'(x)(g_3)(s_3) \wedge apple'(y) \wedge delicious'(y)(g_4)(s_4) \wedge g_4 > g_3]$

According to (62), the meaning of the whole “*yuè... jiù yuè...*” construction in (69) is thus (73).

(73) $\forall [yuè pingguǒ dà][jiù yuè \text{—} pingguǒ hǎo chī]$
 $= \forall x, y, g_1, g_2, s_1, s_2 [apple'(x) \wedge big'(x)(g_1)(s_1) \wedge apple'(y) \wedge big'(y)(g_2)(s_2) \wedge g_2 > g_1]$
 $\Rightarrow \exists g_3 \exists g_4, s_3, s_4 [s_1 \leq s_3 \wedge s_2 \leq s_4 \wedge R(\langle g_1, s_1 \rangle, \langle g_3, s_3 \rangle) \wedge R(\langle g_2, s_2 \rangle, \langle g_4, s_4 \rangle) \wedge$

¹⁹ For a rule quite similar to (70), also see McNally and Boleda (2004)

²⁰ Alternatively, we may assume that the empty subject is a null pronoun which is anaphoric back to its antecedent.

$\text{apple}'(x) \wedge \text{delicious}'(x)(g_3)(s_3) \wedge \text{apple}'(y) \wedge \text{delicious}'(y)(g_4)(s_4) \wedge g_4 > g_3]$

(73) claims that for all x, y, g_1, g_2, s_1, s_2 such that x and y are apples, g_1, g_2 are the degrees of bigness of x and y in situation s_1 and s_2 , respectively and g_2 is greater than g_1 , there exist a g_3, g_4, s_3 and s_4 such that s_3 is an extended situation of s_1 and s_4 an extended situation of s_2 and g_1 of x in s_1 causes g_3 of x in s_3 and g_2 of y in s_2 causes g_4 of y in s_4 and g_4 is greater than g_3 . In other words, we are comparing the different degrees of bigness and deliciousness of different apples.

It should be emphasized that in (69=65) we are comparing two different apples with respect to a given property because the argument of *yuè* is a relation between individuals and degrees. That is, the argument of *yuè* is ‘ $\lambda x \lambda g \dots$ ’ rather than ‘ $\lambda g \dots$ ’. This in turn is due to the fact that the subject noun phrase in (69) is analyzed as having a predicative meaning, which is combined with the predicate of the clause by rule (70).

Another important point to note about (73) is that the adjective *dà* ‘big’ should be understood as an individual-level predicate, which describes the final size of an apple rather than a stage-level predicate, which describes a temporary size. When *yuè* modifies an individual-level predicate and the subject NP is a bare noun, it always compares different individuals’ degrees with respect to a given property. This reading is further corroborated by (74).

(74) nǚháizi yuè piàoliàng , jiù yuè duō rén zhuī
 girls more beautiful than more many man chase
 ‘The more beautiful a girl is, the more men will run after her.’

Such an interpretation of bare nouns and individual-level predicates are actually not a surprise, because individual-level properties do not change over time. This is the reason why it is difficult to compare the same individual’s different degrees of a permanent property, as the oddness of (75) shows.²¹

(75) *Xiǎomíng yuè cōngmíng , māma jiù yuè xǐhuān tā
 Xiaoming more smart mother then more like him
 ‘The more clever Xiaoming is, the more his mother likes him.’

If an individual-level property does not change over time, naturally one cannot compare its different degrees for the same individual. Therefore, if one wants to

²¹ This sentence can be more acceptable if one compares across different possible worlds instead of the actual one.

compare different degrees of an individual-level property, he has to compare different individuals' degrees with respect to that property.

Notice, however, that the AP *dà* 'big' in (69) can also be interpreted as a stage-level predicate. Under this interpretation, the size of bigness modified by *yuè* does not denote a permanent final size of the apple but the gradual change of the shape of the apple. If this interpretation is chosen, (69) can be used to compare the different degrees of the same apple instead of two different apples. In what follows I will discuss how this reading is derived. Again, I will argue that the source of this reading comes from a proper analysis of an NP consisting of a bare noun.

Kamp (1981), Heim (1982), Diesing (1990) and many others have suggested that indefinite noun phrases can be analyzed as free variables accompanied by conditions on assignments to those variables. For instance, 'a girl' can translate as a free variable x plus the condition $girl'(x)$. According to Partee (2004: 206), such a Kamp-Heim approach to indefinites is to treat them as e -type expressions. I will follow Partee in making this assumption and notate the translation as ' $x:girl'(x)$ '.

Returning to Chinese, I assume that NPs consisting of a bare noun is also a type of indefinite and can be analyzed as free variables plus a condition on them. Given the above assumptions, (69) can now be alternatively computed as in (76), where the AP *dà* 'big' is understood as a stage-level predicate meaning a temporary size of an entity and the subject NP is given a Kamp-Heim style treatment of indefinites.

(76) pingguǒ yuè dà jiù yuè hǎochī (Stage-level interpretation of *big*)
apple more big then more delicious

'The bigger an apple becomes, the more delicious it is.'

- a. $[[_{AP} \textit{dà}]] = \lambda x \lambda g \lambda s. \textit{grow-big}(x)(g)(s)$
- b. $[[_{NP} \textit{pingguǒ}]] = x:\textit{apple}'(x)$
- c. $[[\textit{pingguǒ dà}]] = \lambda g \lambda s. \textit{big}'(x:\textit{apple}'(x))(g)(s)$
- d. $[[_{CP} \textit{yuè pingguǒ dà}]] = \lambda g_1 \lambda g_2 \lambda s_1 \lambda s_2 [\textit{big}'(x:\textit{apple}'(x))(g_1)(s_1) \wedge \textit{big}'(x:\textit{apple}(x))(g_2)(s_2) \wedge g_2 > g_1]$
- e. $[[_{CP} \textit{yuè pingguǒ hǎochī}]]$
 $= \lambda g_3 \lambda g_4 \lambda s_3 \lambda s_4 \textit{delicious}'(x:\textit{apple}'(x))(g_3)(s_3) \wedge \textit{delicious}'(x:\textit{apple}')(g_4)(s_4)$
 $\wedge g_4 > g_3]$
- f. $[[_{CP} \forall \textit{yuè pingguǒ dà jiù yuè pingguǒ hǎochī}]]^{22}$
 $= \forall x, g_1, g_2, s_1, s_2 [[\textit{big}'(x:\textit{apple}'(x))(g_1)(s_1) \wedge \textit{big}'(x:\textit{apple}(x))(g_2)(s_2) \wedge g_2 > g_1]$
 $\Rightarrow [\exists g_3 \exists g_4, s_3, s_4 [s_1 \leq s_3 \wedge s_2 \leq s_4 \wedge R(\langle g_1, s_1 \rangle, \langle g_3, s_3 \rangle) \wedge R(\langle g_2, s_2 \rangle, \langle g_4, s_4 \rangle) \wedge$

²² I assume that a lambda operator is first inserted to bind the free variable x (to fix the type mismatch) so that it can be quantified over by the universal quantifier.

delicious'(x:apple'(x))(g₃)(s₃) ∧ delicious'(x:apple')(g₄)(s₄) ∧ g₄>g₃]

Some remarks on the above technical details are in order here. In (76), since the bare noun subject is analyzed as a type *e* variable as in (76b), it can be combined with the AP *dà* ‘big’ directly via functional application. The result of this is an expression of type $\langle d, \langle s, t \rangle \rangle$ as in (76c) rather than type $\langle e, \langle d, \langle s, t \rangle \rangle \rangle$. Therefore, when *yuè* applies to this $\langle d, \langle s, t \rangle \rangle$ expression as in (76d), only the degree argument, but not the individual argument will be lambda converted twice to produce two propositions. Later the free variable introduced by the bare noun subject is bound by the implicit universal quantifier. After the binding of the free variable by the universal quantifier, we obtain the result that two different degrees of bigness of the same individual are compared.²³

In connection with the above analysis, it is interesting to note that Beck (1997:237) has observed that a sentence like (77) might get a reading on which “an attorney is understood generically, and we talk about a development in the sliminess of one and the same attorney (i.e. we are not comparing different attorneys)”. Clearly, this reading of (77) analyzes *slimier* as a stage-level rather than as an individual-level property.

(77) The slimier an attorney looks, the more successful he is.

Beck briefly notes, without arguments, that this reading of (77) can be formalized as (78)

(78) Gen x [attorney(x)][$\forall t_1, t_2$ [x is slimier at t_1 than at t_2]]
 \Rightarrow [x is more successful at t_1 than at t_2]]

Although Beck explicitly says that she wants to disregard this reading from her analysis of comparative conditionals, it is still worthwhile to make some comments on the analysis of (78). A question raised by (78) is that it is not clear how two universal operators are generated at the same time from a given conditional. As far as I know, no one has proposed a theory of conditionals that justifies the postulation of an implicit Gen and \forall simultaneously from the same conditional. Second, it is not clear how and why the indefinite *an attorney* must move out of the scope of a temporal conditional when the predicate is interpreted as a stage-level property. Due to these reasons, I do not explore Beck’s approach when analyzing Chinese comparative

²³ When the time arguments are also added, we will get the result of comparing degrees of bigness at different times. To simplify the matter, I do not represent the time arguments.

correlatives.

To sum up, Chinese comparative correlative constructions have two important properties in their interpretations.

First, when the subject NP is a bare noun and the predicate is an individual-level property, the construction can compare the different degrees of that individual-level property only with respect to different individuals but not with respect to the same individual. This is because an individual's permanent property does not change over time.

Second, when the subject NP is a bare noun and the predicate is a stage-level property, the construction tends to compare the different degrees of the stage-level property with respect to the same individual instead of a comparison of different individuals. This is further supported by (79) and (80).

(79) rén yuè máng jiù yuè róngyì shēngbìng

man more busy then more easy get-sick

'The busier a man is, the easier it is for him to get sick.'

(80) xuéshēng yuè jǐnzhāng jiù yuè róngyì kǎo de bù hǎo

student more nervous then more easy take-exam DE not good

'The more nervous a student is, the easier it is for him to not do well in the exam.'

Most native speakers that I consulted agree that the dominating reading of (79) and (80) is one which compares the different degrees of nervousness of the same individual. Many of them have difficulties in getting the reading which compares the different degrees of nervousness of different individuals but accept such a reading with a stronger contextual support. In light of this difference, I think that it is reasonable to say that the first reading is the unmarked one, whereas the second reading is a marked one.

If the native speakers' intuitions and my analysis of the relevant data are correct, then we may arrive at the following generalizations for Chinese comparative correlatives:

- (81) (A) When the subject NP is a bare noun and the predicate is a stage-level property, a treatment of the bare noun subject as a type e free variable is prior to analyzing them as a predicative expression of type $\langle e, t \rangle$.
- (B) When the subject NP is a bare noun and the predicate is an individual-level property, the bare noun subject must be analyzed as a predicative expression of type $\langle e, t \rangle$.

I believe that the above two generalizations about the “*yuè... yuè...*” constructions in Chinese need not be stipulated and can be derived from a general theory of semantic interpretation. In what follows, I will attempt at an explanation of the two generalizations using Partee’s suggested processing strategy for sentence interpretation.

In her famous article “Noun Phrase Interpretation and Type-shifting Principles”, Partee (2004) has made the following suggestion for noun phrase interpretation:

- (82) there is a general processing strategy of trying lowest types first, using higher types only when they are required in order to combine meanings by available compositional rules. (Partee 2004: 204-205)

I would like to suggest that the two generalizations in (81) about Chinese comparative correlatives follow from the above general processing strategy. Consider the generalization (81A) first. We now know that NPs consisting of a bare noun can be analyzed either as free variables of type e or as predicative expressions of type $\langle e, t \rangle$.²⁴ On the other hand, in this article APs or VPs are analyzed as type $\langle e, \langle d, \langle s, t \rangle \rangle \rangle$ expressions. Now according to the processing strategy in (82), the type e meaning of bare noun subjects should be tried first when they are combined with their predicate. This choice then facilitates functional application and no special composition rule is needed. On the other hand, the $\langle e, t \rangle$ meaning of bare noun NPs is forced only when we want to combine the bare noun subject and the predicate by a special composition rule like (70). Partee did not further discuss the implication of the general processing strategy in (82), but it seems quite plausible to say that the general processing strategy actually reflects the degree of difficulty in processing the interpretation of a sentence. Namely, the less costly a strategy takes, the easier it is to process the sentence using that strategy. Or to use the term ‘prior’, the implication of Partee’s suggestion is that when a processing strategy must be chosen prior to another one, the reading obtained from the priority strategy is the one that is more salient or unmarked. If this view is correct, it then follows from the proposed analysis of *yuè* that when the predicate of a bare noun subject is a stage-level property, the reading of comparing the same individual is more striking or easier to get than the one

²⁴ The $\langle e, t \rangle$ meaning of a NP consisting of a bare noun is supported by examples like (i)

- (i) tā shì lǎoshī
 he be teacher
 ‘He is a teacher.’
- (ii) wǒ shāndōng-rén
 I Shandong-person
 ‘I am from Shandong.’

comparing different individuals, because the first reading utilizes a more simple semantic object and a cost-free strategy, whereas the second reading employs a more complicated semantic type and a special compositional rule.

As for the generalization (81B), in principle, when the predicate of a bare noun subject is an individual-level property, we should also try the possible lowest type first. However, if we analyze the bare noun subject as an *e*-type free variable, i.e., the lowest type possible, this leads to a pragmatically odd and semantically contradictory interpretation in which a permanent individual-level property may change over time. It is exactly due to this reason that in a “*yuè... yuè...*” construction, the bare noun subject of an individual-level property is forced to be analyzed as a type $\langle e, t \rangle$ expression, the possible lowest type next to type *e* expressions and to make use of a non-functional application rule such as (70) to do the semantic composition. Therefore, we get the reading which compares different individuals.

Above, I have discussed the *e* and $\langle e, t \rangle$ uses of a bare noun NP to explain the two generalizations in (81). However, one might wonder why the $\langle e, t \rangle, t \rangle$, i.e., the generalized quantifier use, is left out. This is because I am not sure that bare noun NPs in Chinese have this meaning. Let us consider the example in (83).

- (83) Jǐngchá zài nàbiān
 Policeman at there
 ‘The policeman is over there./*A policeman is over there.’

(83) has a reading on which the bare noun subject is understood as a definite, referring to a specific policeman that both of the hearer and speaker know about. However, it cannot be understood as a statement about existence of a policeman. Namely, the bare noun subject cannot be interpreted as a generalized quantifier of the following type: $\lambda P \exists x[\text{policeman}'(x) \wedge P(x)]$. To express an existential reading, the existential operator *yǒu* ‘have’ must be used as in (84).

- (84) yǒu jǐngchá zài nàbiān
 Have policeman at there
 ‘There are policemen over there.’

The obligatory presence of the existential operator *yǒu* ‘have’ in (84) indicates that Chinese bare noun NPs are better analyzed as free variables or predicative expressions.²⁵ Both possibilities allow *yǒu* ‘have’ to do the existential binding.²⁶

²⁵ Also see also Cheng (1994) for a discussion of this point.

²⁶ We do get an existential reading of bare noun NP in object position. However, such existential readings are arguably derived from binding by an existential operator adjoined to VP as in Diesing

Even if the generalized quantifier interpretation is possible for Chinese bare noun NPs, such an interpretation will not be used in Chinese comparative correlatives. This is because, as noted, the general processing strategy of sentence meaning is to try lowest types first, using higher types only when they are required. Since e and $\langle e, t \rangle$ are types lower than $\langle \langle e, t \rangle, t \rangle$, the former will be tried before the latter.

6. An Extension to Complex NPs with a Relative Clause

At the outset of this article, it was mentioned that comparative correlatives in Chinese usually take the form of two independent clauses, one being placed before the other. However, as Hsiao (2003) has observed, this is not the only form of comparative correlatives. A “*yuè... yuè...*” construction may also take the following form, where the first *yuè* is inside a relative clause and the second *yuè* modifies the main predicate.

- (85) [CP[IP[DPi[CP t_j yuè jǐnzhāng de xuéshēng]][I^r jiù yuè róngyì t_i kǎo de bù hǎo]]²⁷
 more nervous Rel student then more easy take-exam not good
 ‘lit. Students who are more nervous are more likely to do bad in their exams.’

Such constructions raise two important questions. The first one is related to the interpretation of the sentence. (85) is the complex NP version of the normal comparative correlative in (80). However, the interpretation of (85) greatly differs from (80). As noted, the dominating reading of (80) is to compare the different degrees of nervousness of the same individual. Curiously enough, this is not the reading of (85). For almost every native speaker that I consulted, (85) is used to compare the degrees of nervousness of different individuals. A question thus immediately arises as to why this is the case. A second question is: Can the reading be derived from the above proposed analysis of Chinese comparative correlatives? These are the tasks to which I now turn.

Let us assume that like normal “*yuè... yuè...*” constructions, (85) is also mapped to a tripartite structure with an implicit universal operator as the quantifier in Logical Form. Furthermore, let us assume that the subject NP is mapped to the restriction of the quantifier and the VP to the nuclear scope. Since the subject NP is raised from the VP-internal position to the specifier position of IP, there is a lambda operator binding the original subject position. Finally, let us also assume that the two occurrences of *yuè* are adjoined to the restriction and the nuclear scope, respectively and *jiù* is further adjoined to the top of *yuè*. Then the Logical Form of (85) looks like (86).

(1990)

²⁷ In this article, I assume the VP-internal subject hypothesis.

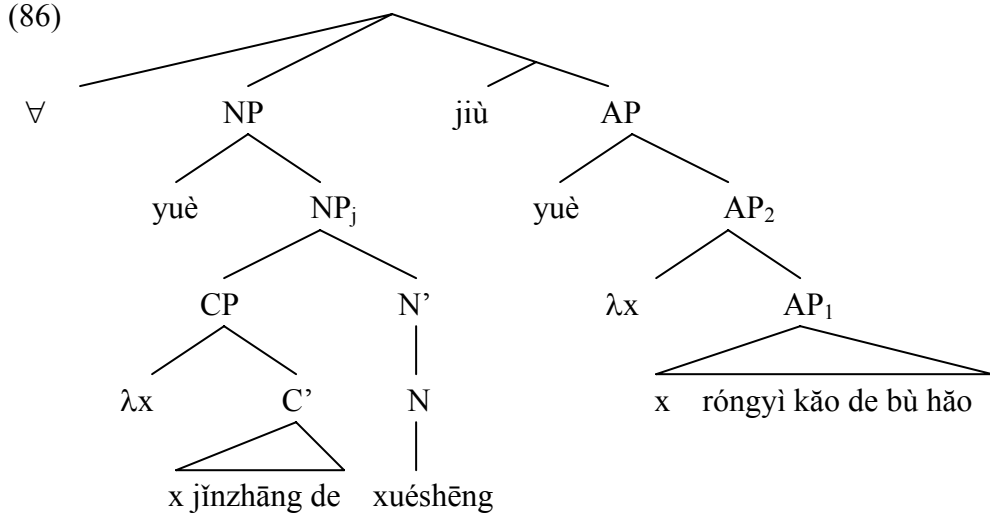

The semantic computation of (86) is (87):

- (87)
- a. $[[C']] = \lambda g \lambda s. \text{nervous}'(x)(g)(s)$
 - b. $[[CP]] = \lambda x \lambda g \lambda s. \text{nervous}'(x)(g)(s)$
 - c. $[[N]] = [[N']] = \lambda x. \text{student}'(x)$
 - d. $[[NP_j]] = \lambda x \lambda g \lambda s [\text{nervous}'(x)(g)(s) \wedge \text{student}'(x)]$
 - e. $[[NP]] = [[yuè NP_j]] = \lambda x \lambda y \lambda g_1 \lambda g_2 \lambda s_1 \lambda s_2 [\text{nervous}'(x)(g_1)(s_1) \wedge \text{student}(x) \wedge \text{nervous}'(y)(g_2)(s_2) \wedge \text{student}'(y) \wedge g_2 > g_1]$
 - f. $[[AP_1]] = [[x róngyì kǎo de bù hǎo]] = \lambda g \lambda s. \text{easy-do-bad-in-exam}'(x)(g)(s)$
 - g. $[[AP_2]] = \lambda x \lambda g \lambda s. \text{easy-do-bad-in-exam}'(x)(g)(s)$
 - h. $[[yuè AP_2]] = \lambda x \lambda y \lambda g_3 \lambda g_4 \lambda s_3 \lambda s_4 [\text{easy-do-bad-in-exam}'(x)(g_3)(s_3) \wedge \text{easy-do-bad-in-exam}'(y)(g_4)(s_4) \wedge g_4 > g_3]$
 - i. $[[\forall yuè jǐnzhāng de xuéshēng jiù yuè róngyì kǎo de bù hǎo]]$
 $= \forall x, y, g_1, g_2, s_1, s_2 [\text{nervous}'(x)(g_1)(s_1) \wedge \text{student}'(x) \wedge \text{nervous}'(y)(g_2)(s_2) \wedge \text{student}'(y) \wedge g_2 > g_1]$
 $\Rightarrow \exists g_3 \exists g_4, s_3, s_4 [s_1 \leq s_3 \wedge s_2 \leq s_4 \wedge R(\langle g_1, s_1 \rangle, \langle g_3, s_3 \rangle) \wedge R(\langle g_2, s_2 \rangle, \langle g_4, s_4 \rangle) \wedge \text{easy-do-bad-in-exam}'(x)(g_3)(s_3) \wedge \text{easy-do-bad-in-exam}'(y)(g_4)(s_4) \wedge g_4 > g_3]$

As we can see from the last step in (87), the final translation is a claim about the comparison of different individuals' degrees of nervousness instead of a comparison of the same individual's different degrees of nervousness. This interpretation is a consequence of the phrase structure and can be explained as follows. Suppose that the free variable analysis, i.e., type e analysis, of indefinites applies only to full indefinite

NPs.²⁸ Then this analysis is inapplicable to the noun *xuéshēng* ‘student’ in (86), because *xuéshēng* ‘student’ in (86) at most constitutes a N’. In contrast, there is no problem with the treatment of the bare noun as a type $\langle e, t \rangle$ predicate. When this is the case, the meaning of N’ can be combined through rule (70) with the meaning of the relative clause, which is a type $\langle e, \langle d, \langle s, t \rangle \rangle \rangle$ expression and produce another expression of type $\langle e, \langle d, \langle s, t \rangle \rangle \rangle$. Consequently, when this expression serves as the argument of *yuè*, two different individuals x and y , and two different degrees g_1 and g_2 , will be used to produce two propositions. Therefore, we obtain the reading on which different individuals are compared with respect to their degrees of nervousness.

7. The Semantics of Comparative Correlatives with an Overt Item of Comparison

It was noted earlier that unlike English comparative conditionals, Chinese comparative correlatives allow an overt item of comparison to occur as (50), reproduced below, shows.

- (50) Nǐ yuè bǐ tā kuàilè , tā jiù yuè tongkǔ
 you more compare he happy he then more painful
 ‘*The happier you are than he, the more painful he is.’
 ‘The more your happiness exceeds his,, the more painful it is for him.’

In this section, I will show that the proposed semantics of *yuè* may apply to (50), given a proper analysis of the comparison morpheme *bǐ*. It should be noted that I do not intend to provide a comprehensive treatment of Chinese comparative constructions. So my treatment of *bǐ* will be just minimally sufficient to serve the purpose of discussing examples like (50).

I propose that sentences with *bǐ* has a structure like (88) and *bǐ* has a semantics like (89). The computation of (88) is therefore (90).

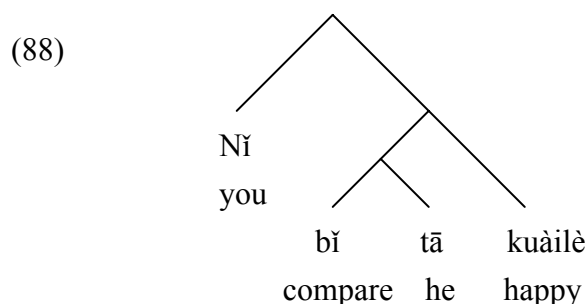

$$(89) [[bǐ]] = \lambda x \lambda P_{\langle e, \langle d, \langle s, t \rangle \rangle} \lambda y \lambda g_2 \lambda s. \exists g_1 [P(x)(g_1)(s) \wedge P(y)(g_2)(s) \wedge g_2 > g_1]$$

$$(90) [[bǐ tā]] = \lambda P_{\langle e, \langle d, \langle s, t \rangle \rangle} \lambda y \lambda g_2 \lambda s \exists g_1 [P(\text{he}') (g_1)(s) \wedge P(y)(g_2)(s) \wedge g_2 > g_1]$$

²⁸ I think that this assumption is implicitly made by Kamp (1981), Heim (1982) and Diesing (1990).

$$[[b\bar{i} \bar{t}\bar{a} \text{ ku}\bar{a}\bar{i}\bar{l}\bar{e}]] = \lambda y \lambda g_2 \lambda s \exists g_1 [\text{happy}'(\text{he})(g_1)(s) \wedge \text{happy}'(y)(g_2)(s) \wedge g_2 > g_1]$$

$$[[N\bar{i} \bar{b}\bar{i} \bar{t}\bar{a} \text{ ku}\bar{a}\bar{i}\bar{l}\bar{e}]] = \lambda g_2 \lambda s \exists g_1 [\text{happy}'(\text{he})(g_1)(s) \wedge \text{happy}'(\text{you}')(g_2)(s) \wedge g_2 > g_1]$$

If there is no other element on the top of the representation, existential closure will apply to close the g_2 and situation variable, giving rise to the interpretation that he is g_1 -degree happy in situation s and you are g_2 -degree happy in situation s and g_2 is greater than g_1 . This seems to be intuitively correct.

Now if on the top of the representation of (88), we have the word *yuè*, the computation will continue as follows:

$$(91) [[yuè \bar{n}\bar{i} \bar{b}\bar{i} \bar{t}\bar{a} \text{ ku}\bar{a}\bar{i}\bar{l}\bar{e}]]$$

$$= \lambda P_{\langle d, \langle s, t \rangle \rangle} \lambda g_5 \lambda g_6 \lambda s_5 \lambda s_6 [P(g_5)(s_5) \wedge P(g_6)(s_6) \wedge g_6 > g_5] (\lambda g_2 \lambda s \exists g_1 [\text{happy}'(\text{he})(g_1)(s) \wedge \text{happy}'(\text{you}')(g_2)(s) \wedge g_2 > g_1])$$

$$= \lambda g_5 \lambda g_6 \lambda s_5 \lambda s_6 [\exists g_1 [\text{happy}'(\text{he})(g_1)(s_5) \wedge \text{happy}'(\text{you}')(g_5)(s_5) \wedge g_5 > g_1] \wedge \exists g_2 [\text{happy}'(\text{he})(g_2)(s_6) \wedge \text{happy}'(\text{you}')(g_6)(s_6) \wedge g_6 > g_2 \wedge g_6 > g_5]]$$

The last line of (91) amounts to saying that you are g_5 -degree happy in s_5 and he is g_1 degree happy also in s_5 and g_5 is greater than g_1 and you are g_6 -degree happy in s_6 and he is g_2 degree happy also in s_6 and g_6 is greater than g_2 and g_6 is also greater than g_5 .

The last step is then to compute the whole construction, which is as follows.

$$(92) [[\forall yuè \bar{n}\bar{i} \bar{b}\bar{i} \bar{t}\bar{a} \text{ ku}\bar{a}\bar{i}\bar{l}\bar{e} \text{ jiù } yuè \bar{t}\bar{a} \text{ tongk}\bar{u}]]$$

$$= \forall g_5, g_6, s_5, s_6 [\exists g_1 [\text{happy}'(\text{he})(g_1)(s_5) \wedge \text{happy}'(\text{you}')(g_5)(s_5) \wedge g_5 > g_1] \wedge \exists g_2 [\text{happy}'(\text{he})(g_2)(s_6) \wedge \text{happy}'(\text{you}')(g_6)(s_6) \wedge g_6 > g_2 \wedge g_6 > g_5]]$$

$$\Rightarrow \exists g_3 \exists g_4, s_3, s_4 [s_5 \leq s_3 \wedge s_6 \leq s_4 \wedge R(\langle g_5, s_5 \rangle, \langle g_3, s_3 \rangle) \wedge R(\langle g_6, s_6 \rangle, \langle g_4, s_4 \rangle) \wedge \text{painful}'(\text{he}')(g_3)(s_3) \wedge \text{painful}'(\text{he}')(g_4)(s_4) \wedge g_4 > g_3]$$

The final truth conditions are thus the following: For every g_5, g_6, s_5 and s_6 such that you are g_5 -degree happy in s_5 and he is g_1 degree happy in s_5 and g_5 is greater than g_1 and you are g_6 -degree happy in s_6 , and he is g_2 -degree happy in s_6 and g_6 is greater than g_2 and g_5 , there exist a degree g_3 in s_3 , caused by (or related to) g_5 in s_5 and a degree g_4 in s_4 , caused by (or related to) g_6 in s_6 and g_4 and g_6 are degrees of his painfulness and g_4 is greater than g_3 . It seems to me that the truth conditions are intuitively correct. The proposed semantics of *yuè* thus successfully account for the co-occurrence between *yuè* and an overt item of comparison, which is simply impossible on Beck's analysis of *the* for English comparative correlatives.

8. Concluding Remarks

This paper has argued that Hsiao's (2003) proposed semantics for Chinese comparative correlatives in terms of the notion of proportion is inadequate and that Beck's (1997) semantics for English comparative conditionals, which involves reference to comparison of times, worlds and individuals, cannot be extended to account for the Chinese data. Therefore, a completely new analysis of *yuè* is proposed, according to which comparison of degrees is related to different or the same individual, time or situation. The different interpretations of comparative correlatives, i.e., comparison of the same individual's or different individuals' degrees of a given property, are shown to be consequences of Partee's general processing strategy for noun phrase interpretation as well as the constituent structure of the sentence. This new analysis of comparative correlatives, though quite successful in accounting for the Chinese data, leaves us wondering whether it is still possible to maintain a universal semantics of comparative correlatives and explain the variability in some other way. In what follows I will outline a potential direction that may achieve this goal.

If the proposed analysis of Chinese *yuè* is correct, the best strategy for a universal semantics of comparative correlatives is that other languages employ the same semantics as *yuè* and the observed cross-linguistic variation can be attributed to independent factors. Indeed, I would like to suggest that this is possibly the case and the cross-linguistic variation is due to syntactic differences between different languages. There are at least the following syntactic differences between Chinese and English-kind comparative correlatives:

- (A) The morpheme *the* is present in the DegP in English comparative correlatives, whereas there doesn't seem to exist such a morpheme in Chinese comparative correlatives.
- (B) English comparative correlatives involve overt syntactic movement of the 'the Adj-er' constituent, whereas Chinese comparative correlatives do not have such a movement.
- (C) English comparative correlatives do not allow an overt item of comparison, whereas Chinese comparatives do.

The second difference, I think, can be attributed to the fact that English employs overt wh-movement, whereas Chinese lacks overt wh-movement and I will not address this issue. As for the first and third differences, they are, in all likelihood, related to each

other. Following Beck (1997), I assume that *-er* heads a degree phrase which takes an adjective as its complement and *the* as the specifier. Moreover, I propose that *the* is syntactically a DP bound by the subject and semantically is a subject copy in disguise. Namely, *the* denotes the same thing as the subject of IP. On these assumptions, the surface structure of an English comparative correlative looks roughly like the following:

(93) a. The busier John is, the happier I am.

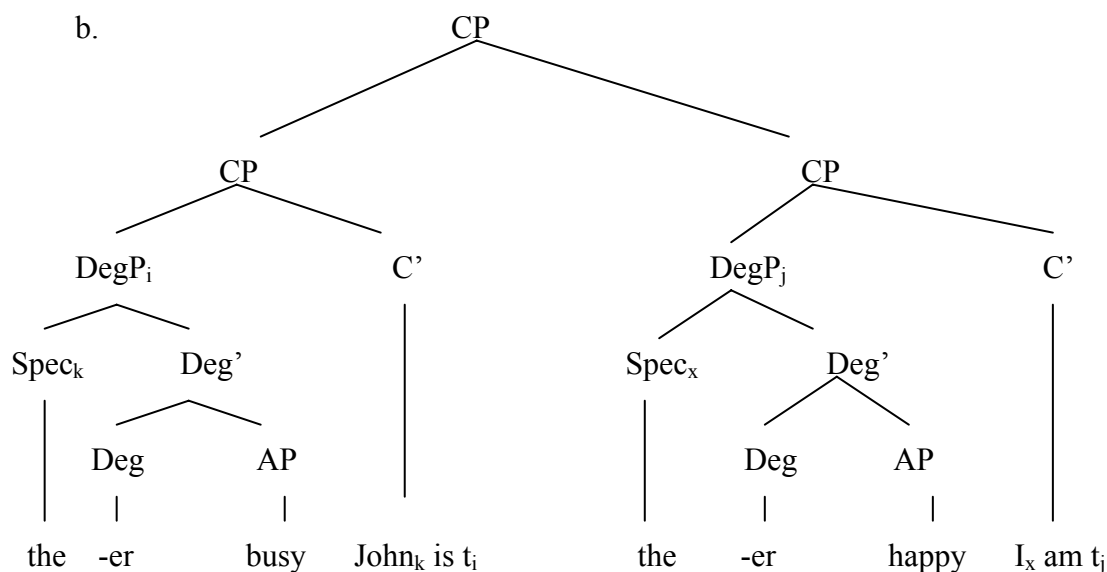

However, at LF, the input of semantic interpretation, the DegP is reconstructed back to its launching site (possibly because the predicate AP must be within the scope of tense and *the* must be bound).²⁹ Therefore, the ultimate LF is (94).

²⁹ The reconstruction is possibly not necessary, as long as semantic composition can be done. However, for the sake of simplicity, I will make this assumption.

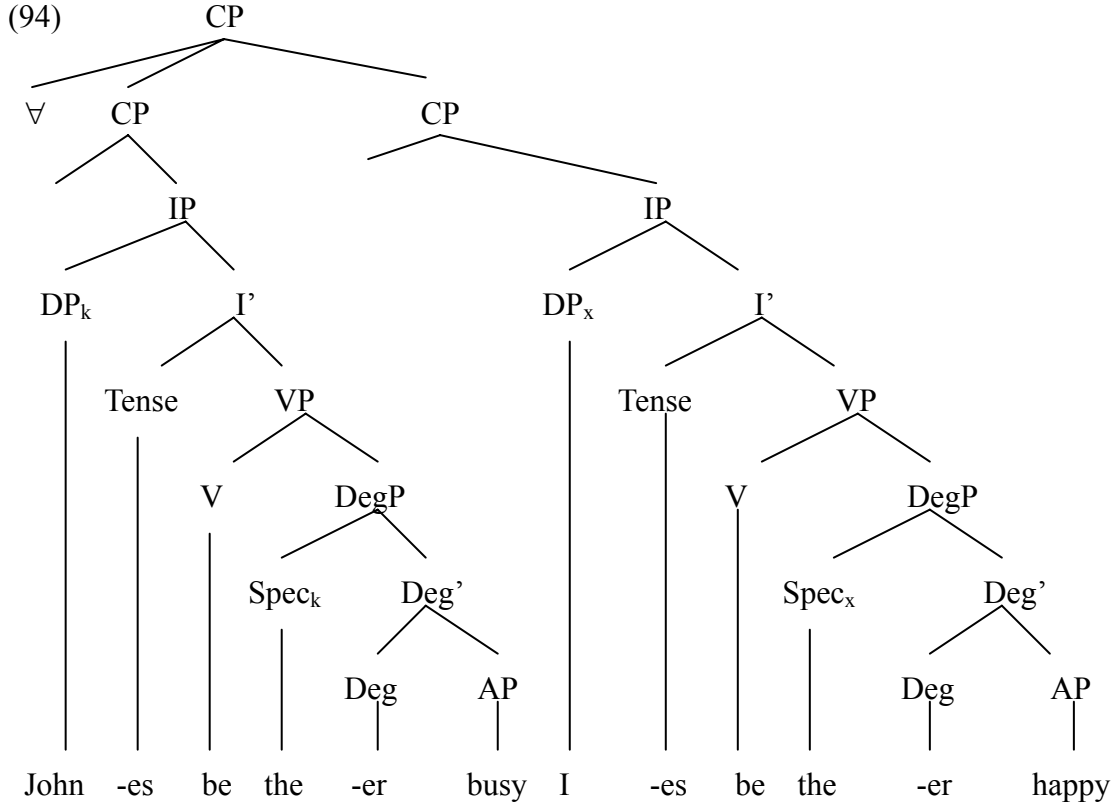

Now assume that the *-er* in the above structure has exactly the same denotation as *yuè* in Chinese. Then the semantic computation of the restrictive clause is the following, ignoring the contribution of tense and the copular verb *be*.

- (95) a. $[[AP]] = \lambda x \lambda g \lambda s. \text{busy}(x)(g)(s)$
 b. $[[Deg']] = [[-er]](\lambda x \lambda g \lambda s. \text{busy}(x)(g)(s))$
 $= \lambda x_1 \lambda x_2 \lambda g_1 \lambda g_2 \lambda s_1 \lambda s_2. [\text{busy}'(x_1)(g_1)(s_1) \wedge \text{busy}'(x_2)(g_2)(s_2) \wedge g_2 > g_1]$
 c. $[[the]] = \text{John}'$
 d. $[[DegP]] = [[Deg']]([[the]])$
 $= \lambda x_2 \lambda g_1 \lambda g_2 \lambda s_1 \lambda s_2. [\text{busy}'(\text{John}')(g_1)(s_1) \wedge \text{busy}'(x_2)(g_2)(s_2) \wedge g_2 > g_1]$
 e. $[[IP]] = \lambda g_1 \lambda g_2 \lambda s_1 \lambda s_2. [\text{busy}'(\text{John})(g_1)(s_1) \wedge \text{busy}'(\text{John})(g_2)(s_2) \wedge g_2 > g_1]$

At this stage, the denotation of the restrictive clause looks exactly like that of the restrictive clause of the Chinese comparative correlative. The same applies to the nuclear scope. The degree and situation variables are then bound by the default universal quantifier, obtaining the following translation:

- (95) f. $\forall g_1, g_2, s_1, s_2. [\text{busy}'(\text{John}')(g_1)(s_1) \wedge \text{busy}'(\text{John}')(g_2)(s_2) \wedge g_2 > g_1]$

$$\Rightarrow \exists g_3 \exists g_4, s_3, s_4 [s_1 \leq s_3 \wedge s_2 \leq s_4 \wedge \text{happy}'(I')(g_3)(s_3) \wedge \text{happy}'(I)(g_4)(s_4) \wedge g_4 > g_3]$$

It is important to note that on the above analysis, the function of the morpheme *the* is to saturate the compared argument, i.e., the variable x_1 of the first proposition, in contrast to the subject DP which saturates the comparing argument, i.e., the variable x_2 of the second proposition. This then predicts that an overt item of comparison such as *than Bill* is impossible, because *the* and *than Bill* compete for the same argument position. We thus explain an important syntactic difference between English and Chinese comparative correlatives. Chinese comparative correlatives allow an overt item of comparison, precisely because no morpheme like *the* saturates the compared argument in syntax. So we see that it is possible to give English and Chinese comparative correlatives a unifying analysis, at the same time explaining the superficial syntactic difference through independent factors.

In (93) and (94), the subject of the restrictive clause is a definite NP. When the subject NP is an indefinite NP as in (96), a similar analysis can be given.

(96) The more nervous a student is in a test, the worse his performance will be.

This sentence seems to have two interpretations. One interpretation compares the degrees of nervousness of the same student and the other one compares the degrees of nervousness of different students. The first interpretation can be easily derived as follows. The indefinite NP is analyzed as a free variable with a condition on it, i.e., ‘ x :student(x)’ in terms of the notation used in this paper. The morpheme *the* also denotes ‘ x :student(x)’. Since the variable denoted by *the* and the variable denoted by the subject are the same one, we get the reading of comparing the same individual when the variables are bound by the default universal quantifier. On the other hand, suppose that instead of translating as ‘ x :student(x)’, the morpheme *the* may also translate as ‘ y :student(y)’. This possibility is not surprising if we think of the morpheme *the* as just another copy of the indefinite DP in subject position. An indefinite analyzed as a free variable can freely translate as ‘ x :student(x)’ or ‘ y :student(y)’ or any variable one prefers to pick. When the variable introduced by the disguised indefinite, i.e., the morpheme *the*, is different from the variable introduced by the indefinite subject DP, we get the interpretation on which the comparing argument and the compared argument are different. Therefore, different individuals instead of the same individual are compared in this case. I conclude that under some plausible assumptions it is not a problem to extend the proposed analysis of *yuè* to English *-er* with respect to comparative correlatives, though the exact compositional process of the constructions in the two languages might not look exactly alike due to

the syntactic differences of the two languages.

Above I have outlined a possible direction of a unifying analysis of cross-linguistic comparative correlatives. Though the suggestion remains somewhat sketchy, it does look very promising and is certainly worth more exploration in the future. However, a caveat about the analysis is in order. Namely, the unifying analysis of cross-linguistic comparative correlative constructions is achieved at the cost of a dual semantics of the comparative morpheme *-er*, because the *-er* as occurs in comparative correlatives does not seem to use the same semantics as the *-er* as occurs in standard comparative sentences. This is in contrast to Beck's endeavor to maintain a uniform semantics of *-er* across constructions. Despite this, I am not sure that this is a real disadvantage in that lexical items often have different semantics depending upon the contexts in which they appear and type-shifting may be used to derive one meaning from another. I suppose that this is also the case for the morpheme *-er* and conclude that it is possible to extend the new semantics of *yuè* for Chinese comparative correlatives to similar constructions in other languages, though the constructions may look syntactically different and involve slightly different compositional process.

Author's address

Department of Foreign Languages and Literatures
National Chiao Tung University
1001 Ta Hsueh Road
Hsinchu, Taiwan
e-mail: jowang@mail.nctu.edu.tw

Acknowledgements

*I am indebted to Professors Paul Portner and Cheng-sheng Liu for their comments and discussions on previous versions of this paper. I would also like to thank the reviewers for suggesting changes that have greatly improved the quality of this paper. The research of this paper was supported by MOE ATU Program and a NSC Grant from Taiwan.

References

- Barker, Chris (2002), The dynamics of vagueness. *Linguistics and Philosophy* **25**:1–36.
- Beck, Sigrid (1997), On the semantics of comparative conditionals. *Linguistics and Philosophy* **20**: 229-271.
- Borsley, Robert D. (2004), An approach to English comparative correlatives. In Stepfan, Müller (ed.), *Proceedings of the 11th International Conference on Head-Driven Phrase Structure Grammar*. CSLI Publications. Stanford, 70-92.
- Culicover, Peter, & Ray Jackendoff (1999), The view from the periphery: the English comparative correlative. *Linguistic Inquiry* **30**: 543–571.
- Cheng, L. S. Lisa (1994), Wh-words as polarity items. *Chinese Languages and Linguistics* **2**: 615-640.
- Cheng, L. S. Lisa, & C.T. James Huang (1998), Two types of donkey sentences. *Natural Language Semantics* **4**: 121-163.
- Cresswell, Max J. (1976), The semantics of degree. In Barbara H. Partee (ed.), *Montague Grammar*, Academic Press, New York.
- Dikken, Marcel den (2005), Comparative correlatives comparatively. *Linguistic Inquiry* **36**: 497-532.
- Doetjes, Jenny Sandra (1997), *Quantifiers and Selection: On the Distribution of Quantifying Expressions in French, Dutch and English*. ICG Printing, Dordrecht.
- Fillmore, Charles J. (1987), Varieties of conditional sentences. *ESCOL* **3**:163-182.
- von Fintel, Kai (1994), *Restrictions on Quantifiers Domains*. Unpublished Ph.D. thesis. Department of Linguistics. University of Massachusetts. Amherst, MA.
- Graff, Delia (2000), Shifting sands: an interest-relative theory of vagueness”, *Philosophical Topics* **20**:45–81.
- Heim, Irene (1982), *The Semantics of Definite and Indefinite Noun Phrases*, Unpublished Ph.D. thesis. Department of Linguistics. University of Massachusetts. Amherst, MA.
- Heim, Irene (2001), Degree operators and scope. In C. Féry & W. Sternefeld (eds.), *Audiatur Vox Sapientiae: A Festschrift for Arnim von Stechow*. Akademie Verlag. Berlin. 214-239.
- Heim, Irene & Angelica Kratzer (1998), *Semantics in Generative Grammar*. Blackwell Publishers Inc. Oxford.
- Hsiao, Su-ying (2003), On proportional correlative constructions in Chinese and Mongolian, *Journal of Taiwanese Languages and Literature* **1**: 243-272.

- Kamp, Hans (1981), A theory of truth and semantic interpretation. In Jeroen Groenendijk, Theo Janssen, & Martin Stokhof (eds.), *Formal Methods in the Study of Language: Proceedings of the Third Amsterdam Colloquium: Part I*. Mathematical Centre Tracts. Amsterdam. 277-321.
- Kennedy, Christopher (2005), Parameters of comparison. Unpublished MS. Department of Linguistics, University of Chicago.
- Kennedy, Christopher & Louise McNally (2005), Scale structure and the semantic typology of gradable predicates. *Language* **81**:345–381.
- Lewis, David (1970) “General semantics”, *Synthese* 22:18–67.
- Lewis, David (1975), Adverbs of quantification, In Edward Keenan (ed.), *Formal Semantics of Natural Language*. Cambridge University Press. Cambridge. 3-15.
- Lin, Jo-wang (1996), *Polarity Licensing and Wh-phrase Quantification in Chinese*, Unpublished Ph.D. thesis. Department of Linguistics. University of Massachusetts. Amherst, Massachusetts.
- Liu, Chen-Sheng Luther (2006), Polarity items in Chinese comparative Conditionals. Paper presented in the 14th Annual Conference of the International Association of Chinese Linguistics. 25-28, May 2006. Academia Sinica, Taipei.
- Lü, Shu-xiang (1982) *Zhongguo Wenfa Yaolüe* [The Basics of Chinese Grammar], Shangwu Yingshuguan. Beijing.
- McCawley, James D (1988), The comparative conditional constructions in English, German and Chinese. *Proceedings of the 14th Annual Meeting of the Berkeley Linguistic Society*:176-187.
- McNally, Louis & Gemma Boleda (2004), Relational adjectives as properties of kinds”, In O. Bonami, & P. Cabredo Hofherr (eds.), *Empirical Issues in Formal Syntax and Semantics 5: Papers from CSSP 2003*. 179-196.
- Partee, H. Barbara (2004), Noun phrase interpretation and type-shifting principles. In *Compositionality in Formal Semantics: Selected Papers by Barbara, H. Partee*. Blackwell. Malden. 203-230.
- Sybesma, Rint (1999), *The Mandarin VP*. Kluwer Academic Publishers. Dordrecht.
- Thiersch, Craig (1982), The harder they come...: a note on the double comparative construction in English. In Werner Welte (ed.), *Sprachtheorie und angewandte Linguistik. Festschrift für Alfred Wollmann*. Tübinger Beiträge zur Linguistik 195. Narr, Tübingen. 47–65.
- von Stechow, A. (1984), My reaction to Cresswell’s, Hellan’s, Hoeksema’s, and Seuren’s Comments. *Journal of Semantics* **3**: 183–199.
- Wold, Dag (1991), A few properties of the...the comparative constructions. In *Proceedings of the Second Annual Meeting of the Formal Linguistic Society of Midamerica (FLSM2)*. University of Michigan. Ann Arbor. 272-281.
- Xiandai Hanyu Xuci Lishi [Examples and Explanation of the Empty Words of

Modern Chinese] (1982). Shangwu. Beijing.
Xing, Fu-yi (2001) Hanyu Fuju Yanjiu [A Study of Complex Sentences]. Shangwu
Yingshuguan. Beijing.